

2302 2306, 2306-PJ

Battery Simulator Battery/Charger Simulators



- Ultrafast response to transient load currents
- Choice of single- or dual-channel supplies
- Optimized for development and testing of battery-powered devices
- Variable output resistance for simulating battery response (U.S. Patent No. 6,204,647)
- Pulse peak, average, and baseline current measurements
- 100nA DC current sensitivity
- Current step measure function
- Sink up to 3A
- Open sense lead detection
- Built-in digital voltmeter

SERVICES AVAILABLE

2302-3Y-EW	1-year factory warranty extended to 3 years from date of shipment
2306-3Y-EW	1-year factory warranty extended to 3 years from date of shipment
2306-PJ-3Y-EW	1-year factory warranty extended to 3 years from date of shipment
C/2302-3Y-ISO	3 (ISO-17025 accredited) calibrations within 3 years of purchase for Model 2302*
C/2306-3Y-ISO	3 (ISO-17025 accredited) calibrations within 3 years of purchase for Models 2306, 2306-P*

*Not available in all countries

to operate like a discharged rechargeable battery, sinking current from a separate charger or from the Model 2306's charger-simulator channel.

Maximize Test Throughput with Accurate Battery Simulation

The battery-output channels of the Models 2302 and 2306 are designed to simulate the output response of a battery. *This capability, combined with their fast transient response, makes it possible to power the device during testing in exactly the same way as a battery will power the device during actual use.* The output resistance of the Model 2302's and the Model 2306's battery channel can be programmed (with 10mΩ resolution) over the range from 0Ω to 1Ω so that the output resistance can be set to the same level as the output resistance of the battery that powers the device. See **Figure 1**.

Portable wireless devices make great demands on their battery power sources. The battery must source load currents that can jump virtually instantaneously from a standby current level (100–300mA) to a full-power RF transmission current level (1–3A). In other words, the load current on the battery can increase rapidly by a factor of 700–1000%. As a result, the battery voltage drops by an amount equal to the value of the current change multiplied by the battery's internal resistance. The Models 2302 and 2306 power supplies enable test systems to duplicate this voltage drop by programming their output resistance to be equivalent to that of the battery that will power the device. This allows wireless device manufacturers to test their products under the same power conditions that they will encounter in actual use. (See **Figure 2**.)

The single-channel Model 2302 Battery Simulator and dual-channel Model 2306 Battery/Charger Simulator were designed specifically for development and test applications of portable, battery-operated products, such as cellular and cordless telephones, mobile radios, and pagers. These precision power supplies have ultrafast transient response so they can have output characteristics identical to actual batteries. These supplies employ a unique variable output resistance so the voltage output can emulate a battery's response (U.S. Patent No. 6,204,647). They provide stable voltage outputs, even when a device-under-test (DUT) makes the rapid transition from the standby (low current) state to the RF transmission (high current) state. In addition, they can monitor DUT power consumption by measuring both DC currents and pulse load currents. The Model 2302's and the Model 2306's battery-simulator channel can be programmed

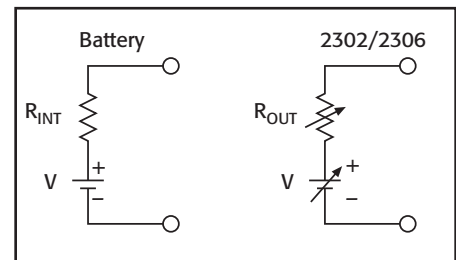

Figure 1. Simplified schematic of a battery and the 2302/2306.

ACCESSORIES AVAILABLE

CABLES

7007-1	Shielded IEEE-488 Cable, 1m (3.3 ft)
7007-2	Shielded IEEE-488 Cable, 2m (6.6 ft)
SC-182	Low-Inductance Coaxial Cable (42nH/ft)

RACK MOUNT KITS

4288-1	Single Fixed Rack Mount Kit
4288-2	Dual Fixed Rack Mount Kit

IEEE-488 INTERFACES

KPCI-488LPA	IEEE-488 Interface/Controller for the PCI Bus
KUSB-488A	IEEE-488 USB-to-GPIB Interface Adapter

2302 2306, 2306-PJ

Ordering Information

- 2302 Battery Simulator
- 2306 Dual-Channel Battery/
Charger Simulator
- 2306-PJ Dual-Channel Battery/
Charger Simulator
with 500mA Range

Accessories Supplied

User and service manuals,
CS-846 output connectors
mating terminal

Conventional Power Supplies and Wireless Device Testing

During production testing, supplying power to a device that undergoes large, instantaneous load current changes can be extremely difficult. Changes like this force a conventional power supply's output voltage to fall instantaneously. When the power supply's control circuitry senses the error condition (the difference in voltage between the programmed level and the actual level), it attempts to correct or restore the voltage to the programmed level. During this time, the voltage will fall or droop substantially, with the amount of the droop depending on the size of the load current change. The recovery time depends on the transient response of the power supply's control loop. Conventional power supplies have transient voltage drops of >1V when confronted with load current changes of up to 1000%, and take up to a millisecond to recover to the programmed voltage. For portable devices such as cellular phones that operate at full power for only short intervals, the full power event is over before the conventional power supply can recover. For example, a cellular phone designed to the GSM cellular phone standard transmits and receives information in 576 μ s pulses. If the power supply used to test these types of phones cannot recover quickly enough, the performance of the phone during testing will be compromised by the power supply. If the power supply voltage drops below the threshold of the phone's low battery detection circuitry for long enough, then the phone will turn off during testing, giving a false indication of a failed device.

Battery Simulator Battery/Charger Simulators

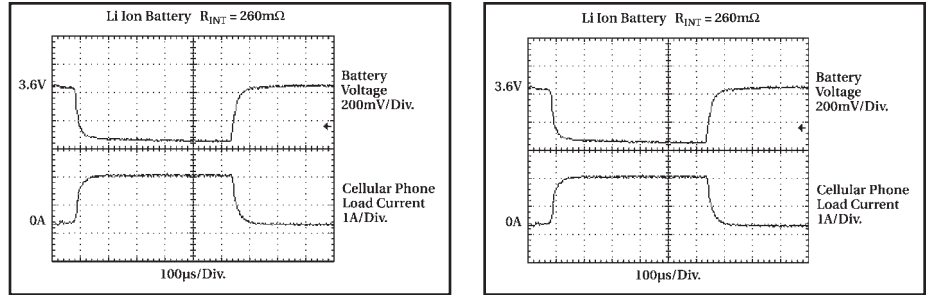

Figure 2. Comparison of the voltage outputs of a lithium-ion battery (with an internal resistance of 260m Ω) and the Model 2306's battery channel (programmed with an output resistance of 260m Ω) when powering a cellular telephone as it makes the transition from standby mode to transmit mode.

In response to large load changes, the Model 2302 and the battery channel of the Model 2306 have transient voltage droops of less than 100mV and transient recovery times of less than 60 μ s, even when the test leads between the power supply and the DUT are long. This fast transient response, combined with the supplies' variable output resistance, allows engineers to test their portable products under the most realistic operating conditions and eliminate false failures due to conventional power supplies with slow response times. (See the sidebar titled "Conventional Power Supplies and Wireless Device Testing.") These supplies also eliminate the large stabilizing capacitors needed at the DUT to compensate for the large droop that occurs when testing with conventional power supplies. By varying the output resistance, which can be done while the output is turned on, test engineers can simulate the operation of different battery types, as well as batteries nearing the end of their useful lives.

The Models 2302 and 2306 ensure maximum production throughput when testing portable

devices by minimizing false failures, minimizing the number of test setups by performing multiple tests with the same power supply, and minimizing test fixture complexity by eliminating the need for voltage-stabilizing capacitors.

Measure Load Currents for Power Consumption Verification or Analysis

As manufacturers of portable devices strive to extend their products' battery life, measuring load currents accurately has become increasingly essential in both design and production test in order to ensure the product meets its demanding specifications. Comprehensive testing of these devices requires measuring peak currents, average currents, and baseline currents in various operation modes. When testing these devices, these measurements are complicated by the pulsating nature of load currents, such as the transmit and receive load currents of digital cellular phones. The Models 2302 and 2306 can measure the peak and average currents of pulses as short as 60 μ s and as long as 833ms. (See Figure 3.)

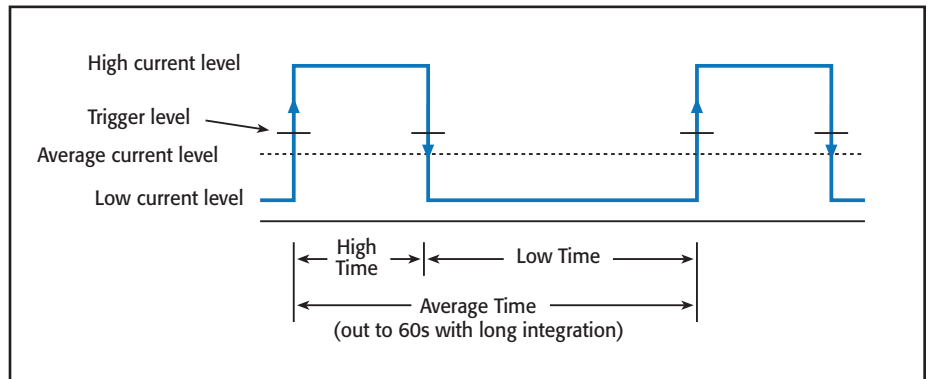

Figure 3. Built-in pulse current measurement functions allow test engineers to measure peak, average, and baseline load currents.

2302 2306, 2306-PJ

Battery Simulator Battery/Charger Simulators

Measure Long-Period Waveform Currents

For pulse trains with periods longer than 850ms, the Models 2302 and 2306 offer a unique, long integration current measurement mode. This mode can provide an average measurement of a current waveform from 850ms up to 60 seconds long.

Measure Low Currents Accurately

The Models 2302 and 2306 are based on Keithley's expertise in low current measurement technologies, so they're well-suited for making fast, accurate measurements of sleep and standby mode currents. With 100nA resolution and 0.2% basic accuracy, they provide the precision needed to monitor the low sleep mode currents of both today's battery-operated products and tomorrow's.

Verify Load Currents in All Operating States

The Models 2302 and 2306 employ a unique pulse current step function for measuring the load current at each level of a device's operational states. (See Figure 4.) For example, if a cellular phone is ramped up and down through as many as 20 discrete power consumption states, the Models 2302 and 2306 can measure the load currents in synchronization with the current steps. This capability allows a test engineer to verify performance at each operational state and simultaneously acquire power consumption information. The fast current measure capability is another way the Models 2302 and 2306 power supplies save test time and production costs.

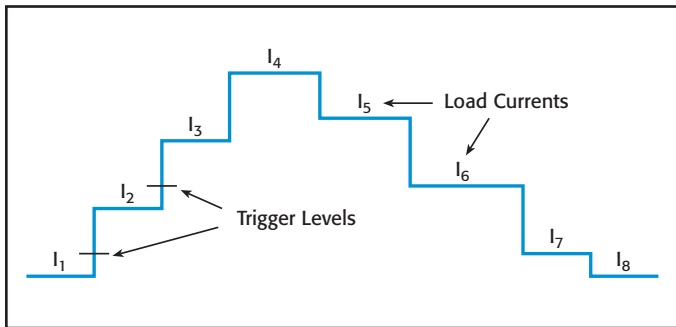

Figure 4. These power supplies can obtain a load current profile synchronized to the transitions of a DUT as it is stepped through its operating states.

Simulate a Discharged Battery for Charger Testing

The Models 2302 and 2306 can sink up to 3A continuously, just like an electronic load. This allows these supplies to simulate a discharged rechargeable battery for use in testing the performance of battery chargers or battery charger control circuitry.

The Model 2306 Battery/Charger Simulator combines the functionality of both the charging current source (the charger channel) and the current sinking to simulate the recharging of a discharged battery (the battery channel) in a single enclosure. (See Figure 5.)

Open-Sense Lead Detection

The Model 2302 and 2306 have an automatic open-sense lead detection capability, which indicates if there is a broken remote sense lead or an open connection from a remote sense lead to the test fixture. To ensure

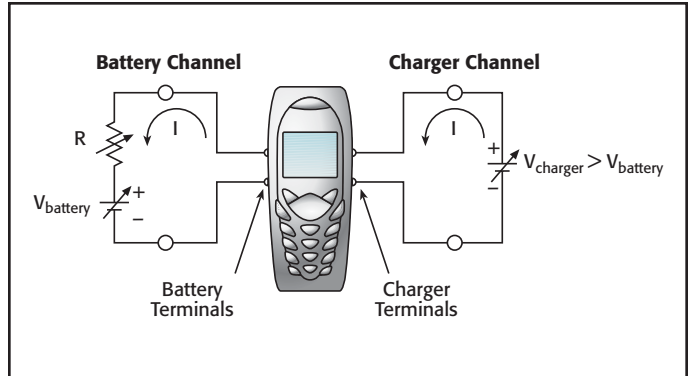

Figure 5. For charger control circuit testing applications, the Model 2306 and 2306-PJ can provide the functions of both a charger-simulating source and a discharged battery simulator.

the output voltage does not change from the programmed level, which could cause production devices to be improperly calibrated, the user can set high and low limits around the desired voltage level.

Independent Digital Voltmeter Inputs

Many programmable power supplies offer output readback capabilities, but the Model 2302 and 2306 also offer DVM inputs. Both instruments allow measuring signals from $-5V$ to $+30V$ DC anywhere in the test system with the same rated accuracy as the voltage readback. The Model 2306 has two sets of DVM inputs; the Model 2302 has one. The DVMs and the power sources can operate simultaneously. For many applications, these built-in DVMs eliminate the expense and space required to add a separate voltage measurement instrument.

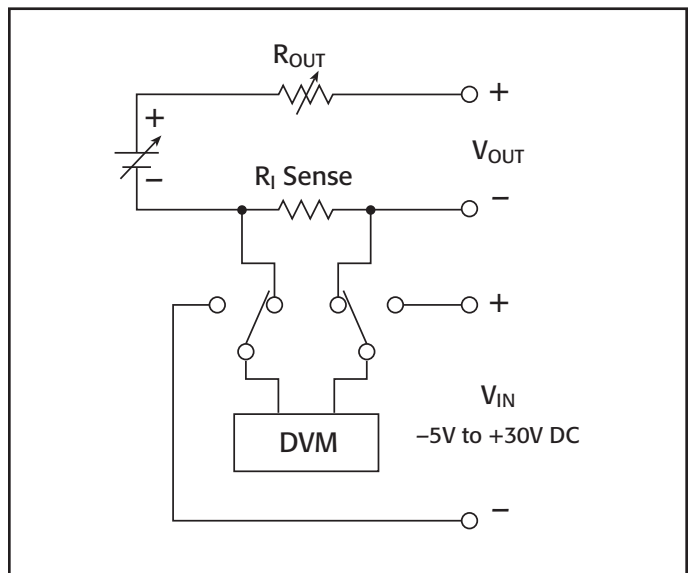

Figure 6. Model 2302 and Model 2306 Battery Channel Block Diagram. The Model 2306 charger channel is identical except it does not have the variable output resistance.

2302 2306, 2306-PJ

Battery Simulator Battery/Charger Simulators

Big Functionality in a Small Package

For high volume production environments where floor and test rack space are at a premium, the Model 2306 packs two power supplies into one half-rack enclosure. In addition to power control, both the Model 2302 and 2306 provide extensive measurement capabilities in the same half-rack case. The front panel of each unit displays the user's choice of either the output voltage and output current, the average, peak, and baseline pulse current levels, long integration currents, or DC DVM measurements. A minimum of front panel buttons ensures that operation is simple and straightforward.

For additional control requirements, the Models 2302 and 2306 each have four digital relay control outputs and a 5V DC output to power a relay coil.

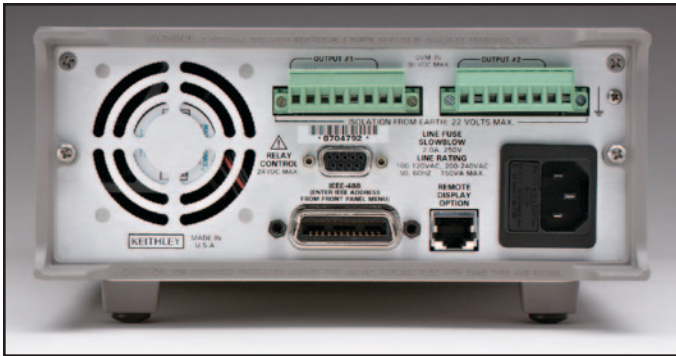

Figure 7. Model 2306 Rear Panel showing 8-position power output connectors, RJ-45 remote display connector, DB-9 relay output connector, IEEE-488 connector, and power input socket.

GENERAL

ISOLATION (low-earth): 22V DC max. For Models 2306 and 2306-PJ, do not exceed 60V DC between any two terminals of either connector.

PROGRAMMING: IEEE-488.2 (SCPI).

USER-DEFINABLE POWER-UP STATES: 5 (4 for Model 2306-PJ).

REAR PANEL CONNECTORS: Two (one for Model 2302) 8-position quick disconnect terminal block for output (4), sense (2), and DVM (2).

TEMPERATURE COEFFICIENT (outside 23°C ±5°C): Derate accuracy specification by (0.1 × specification)°C.

OPERATING TEMPERATURE: 0° to 50°C (Derate to 70%). 0° to 35°C (Full power).

STORAGE TEMPERATURE: -20° to 70°C.

HUMIDITY: <80% @ 35°C non-condensing.

DISPLAY TYPE: 2-line × 16-character VFD.

REMOTE DISPLAY/KEYPAD OPTION: Disables standard front panel.

DIMENSIONS: 89mm high × 213mm wide × 411mm deep (3½ in × 8⅝ in × 16⅜ in).

NET WEIGHT: 3.2kg (7.1 lbs).

SHIPPING WEIGHT: 5.4kg (12 lbs).

INPUT POWER: 100–120V AC/220–240V AC, 50 or 60Hz (auto detected at power-up).

POWER CONSUMPTION: 150VA max.

EMC: 2302, 2306: Conforms with European Union Directive 89/336/EEC, EN 55011, EN 50082-1, EN 61000-3-2 and 61000-3-3, FCC part 15 class B. **2306-PJ:** Conforms with European Union Directive 89/336/EEC.

SAFETY: 2302, 2306: Conforms with European Union Directive 73/23/EEC, EN 61010-1. **2306-PJ:** Conforms with European Union Directive 73/23/EEC.

AC LINE LEAKAGE CURRENT: 450µA @ 110VAC, typ.; 600µA @ 220V, typ.

RELAY CONTROL PORT: 4-channel, each capable of 100mA sink, 24V max. Total port sink capacity (all 4 combined) is 250mA max. Accepts DB-9 male plug.

2302 2306, 2306-PJ

Battery Simulator Battery/Charger Simulators

Output #1 (Battery)

DC VOLTAGE OUTPUT (2 Years, 23°C ± 5°C)

OUTPUT VOLTAGE: 0 to +15V DC.
 OUTPUT ACCURACY: ±(0.05% + 3mV).
 PROGRAMMING RESOLUTION: 1mV.
 READBACK ACCURACY¹: ±(0.05% + 3mV).
 READBACK RESOLUTION: 1mV.
 OUTPUT VOLTAGE SETTLING TIME: 5ms to within stated accuracy.
 LOAD REGULATION: 0.01% + 2mV.
 LINE REGULATION: 0.5mV.
 STABILITY²: 0.01% + 0.5mV.
 MEASUREMENT TIME CHOICES: 0.01 to 10PLC⁷, in 0.01PLC steps.
 AVERAGE READINGS: 1 to 10.
 READING TIME^{1,8,9}: 31ms, typical.
 TRANSIENT RESPONSE: **High Bandwidth** **Low Bandwidth**
 Transient Recovery Time¹³ <40μs³ or <60μs⁴ <80μs³ or <100μs⁴
 Transient Voltage Drop <75mV³ or <100mV⁴ <250mV³ or <400mV⁴

REMOTE SENSE: 1V max. drop in each lead. Add 2mV to the voltage load regulation specification for each 1V change in the negative output lead due to load current change. Remote sense required. Integrity of connection continually monitored. If compromised, output will turn off automatically once settable window (±0 to ±8V) around normal voltage exceeded.

VARIABLE OUTPUT IMPEDANCE

RANGE: 0 to 1.00Ω in 0.01Ω steps. Value can be changed with output on.

DC CURRENT (2 Years, 23°C ± 5°C)

OUTPUT CURRENT (2302):
 0–4V: 5A max.
 >4V: $I_{MAX} = 60W / (V_{OUT} + 6)$ (not intended to be operated in parallel).
 CONTINUOUS AVERAGE OUTPUT CURRENT (2306, 2306-PJ):
 Channel #2 (Charger) OFF:
 $I = 50W / (V_{SET} \text{ channel 1} + 6V)$; 5A max.
 Channel #2 (Charger) ON:
 $I = (50W - \text{Power consumed by channel \#2}) / (V_{SET} \text{ channel 1} + 6V)$; 5A max.
 The power consumed by channel #2 is calculated as:
 Channel #2 sourcing current:
 Power consumed = $(V_{SET} \text{ channel 2} + 6V) \times (\text{current supplied})$
 Channel #2 sinking current:
 Power consumed = $5 \times (\text{sink current})$
 Peak currents can be a maximum of 5A provided the average current is within the above limits.
 CONTINUOUS AVERAGE SINK CURRENT:
 Channel #2 (Charger) OFF:
 0–5V: 3A max.
 5–15V: Derate 0.2A per volt above 5V. Compliance setting controls sinking.
 Channel #2 (Charger) ON:
 Available current = $(50W - \text{Power consumed by channel \#2}) / 5$; 3A max. (0–5V).
 Derate 0.2A per volt above 5V.
 SOURCE COMPLIANCE ACCURACY: ±(0.16% + 5mA)⁵.
 PROGRAMMED SOURCE COMPLIANCE RESOLUTION: 1.25mA.
 READBACK ACCURACY¹: 5A Range: ±(0.2% + 200μA).
 5mA Range: ±(0.2% + 1μA) (2302 and 2306).
 500mA Range: ±(0.2% + 20μA) (2306-PJ only).
 READBACK RESOLUTION: 5A Range: 100μA.
 5mA Range: 0.1μA (2302 and 2306).
 500mA Range: 10μA (2306-PJ only).
 LOAD REGULATION: 0.01% + 1mA.
 LINE REGULATION: 0.5mA.
 STABILITY⁴: 0.01% + 50μA.
 MEASUREMENT TIME CHOICES: 0.01 to 10PLC⁷, in 0.01PLC steps.
 AVERAGE READINGS: 1 to 10.
 READING TIME^{1,8,9}: 31ms, typical.

PULSE CURRENT MEASUREMENT OPERATION

TRIGGER LEVEL:
 5A CURRENT RANGE
 5A Range: 5mA to 5A, in 5mA steps.
 1A Range: 1mA to 1A, in 1mA steps.
 100mA Range: 0.1mA to 100mA, in 100μA steps.
 500mA CURRENT RANGE (2306-PJ)
 500mA Range: 0.5mA to 500mA, in 0.5mA steps.
 100mA Range: 0.1mA to 100mA, in 100μA steps.
 10mA Range: 100μA to 10mA, in 100μA steps.
 TRIGGER DELAY: 0 to 100ms, in 10μs steps.
 INTERNAL TRIGGER DELAY: 15μs.
 HIGH/LOW/AVERAGE MODE:
 Measurement Aperture Settings: 33.3μs to 833ms, in 33.3μs steps.
 Average Readings: 1 to 10.
 PULSE CURRENT MEASUREMENT ACCURACY¹¹ (2 Years, 23°C ± 5°C):

Aperture	Accuracy ±(% reading + offset + rms noise ¹⁰)	
	5A Range	500mA Range (2306-PJ)
<100 μs	0.2% + 900 μA + 2 mA	0.2% + 90 μA + 2 mA
100 μs – 200 μs	0.2% + 900 μA + 1.5 mA	0.2% + 90 μA + 1.5 mA
200 μs – 500 μs	0.2% + 900 μA + 1 mA	0.2% + 90 μA + 1 mA
500 μs – <1 PLC	0.2% + 600 μA + 0.8 mA	0.2% + 60 μA + 0.8 mA
1 PLC ¹²	0.2% + 400 μA + 0 mA	0.2% + 40 μA + 0 mA
>1 PLC	0.2% + 400 μA + 100 μA	0.2% + 40 μA + 100 μA

BURST MODE CURRENT MEASUREMENT

MEASUREMENT APERTURE: 33.3μs.
 CONVERSION RATE: 3650/second, typical.
 INTERNAL TRIGGER DELAY: 15μs.
 NUMBER OF SAMPLES: 1 to 5000.
 TRANSFER SAMPLES ACROSS IEEE BUS IN BINARY MODE: 4800 bytes/s, typical.

LONG INTEGRATION MODE CURRENT MEASUREMENT

2302, 2306: Available on 5A range only.
 2306-PJ: Available on 5A and 500mA current ranges.
 MEASUREMENT TIME⁶: 850ms (840ms) to 60 seconds in 1ms steps.

DIGITAL VOLTMETER INPUT (2 Years, 23°C ± 5°C)

INPUT VOLTAGE RANGE: –5 to +30V DC.
 INPUT IMPEDANCE: 2MΩ typical.
 MAXIMUM VOLTAGE (either input terminal) WITH RESPECT TO OUTPUT LOW: –5V, +30V.
 READING ACCURACY¹: ±(0.05% + 3mV).
 READING RESOLUTION: 1mV.
 CONNECTOR: HI and LO input pair part of Output #1's terminal block.
 MEASUREMENT TIME CHOICES: 0.01 to 10PLC⁷, in 0.01PLC steps.
 AVERAGE READINGS: 1 to 10.
 READING TIME^{1,8,9}: 31ms, typical.

1.888.KEITHLEY (U.S. only)

www.keithley.com

KEITHLEY

A GREATER MEASURE OF CONFIDENCE

2302 2306, 2306-PJ

Battery Simulator Battery/Charger Simulators

OUTPUT #2 (CHARGER)

DC VOLTAGE OUTPUT (2 Years, 23°C ± 5°C)

OUTPUT VOLTAGE: 0 to +15V DC.
 OUTPUT ACCURACY: ±(0.05% + 10mV).
 PROGRAMMING RESOLUTION: 10mV.
 READBACK ACCURACY¹: ±(0.05% + 3mV).
 READBACK RESOLUTION: 1mV.
 OUTPUT VOLTAGE SETTLING TIME: 5ms to within stated accuracy.
 LOAD REGULATION: 0.01% + 2mV.
 LINE REGULATION: 0.5mV.
 STABILITY²: 0.01% + 0.5mV.
 MEASUREMENT TIME CHOICES: 0.01 to 10PLC⁷, in 0.01PLC steps.
 AVERAGE READINGS: 1 to 10.
 READING TIME^{1,8,9}: 31ms, typical.
 TRANSIENT RESPONSE:
 Transient Recovery Time¹³ **High Bandwidth** **Low Bandwidth**
 <50μs³ or <80μs⁴ <60μs³ or <100μs⁴
 Transient Voltage Drop <120mV³ or <150mV⁴ <160mV³ or <200mV⁴

REMOTE SENSE: 1V max. drop in each lead. Add 2mV to the voltage load regulation specification for each 1V change in the negative output lead due to load current change. Remote sense required. Integrity of connection continually monitored. If compromised, output will turn off automatically once settable window (±0 to ±8V) around normal voltage exceeded.

DC CURRENT (2 Years, 23°C ± 5°C)

CONTINUOUS AVERAGE OUTPUT CURRENT:
 Channel #1 (Battery) OFF:
 I = 50W/(V_{SET} channel 2 + 6V); 5A max.
 Channel #1 (Battery) ON:
 I = (50W – Power consumed by channel #1)/(V_{SET} channel 2 + 6V); 5A max.
 The power consumed by channel #1 is calculated as:
 Channel #1 sourcing current:
 Power consumed = (V_{SET} channel 1 + 6V) × (current supplied)
 Channel #1 sinking current:
 Power consumed = 5 × (sink current)
 Peak currents can be a maximum of 5A provided the average current is within the above limits.
 CONTINUOUS AVERAGE SINK CURRENT:
 Channel #1 (Battery) OFF:
 0–5V: 3A max.
 5–15V: Derate 0.2A per volt above 5V. Compliance setting controls sinking.
 Channel #1 (Battery) ON:
 Available current = (50W – Power consumed by channel #1)/5; 3A max. (0–5V).
 Derate 0.2A per volt above 5V.

SOURCE COMPLIANCE ACCURACY: ±(0.16% + 5mA)⁵.
 PROGRAMMED SOURCE COMPLIANCE RESOLUTION: 1.25mA.
 READBACK ACCURACY¹: **5A Range:** ±(0.2% + 200μA).
 5mA Range: ±(0.2% + 1μA).
 READBACK RESOLUTION: **5A Range:** 100μA.
 5mA Range: 0.1μA.
 LOAD REGULATION: 0.01% + 1mA.
 LINE REGULATION: 0.5mA.
 STABILITY²: 0.01% + 50μA.
 MEASUREMENT TIME CHOICES: 0.01 to 10PLC⁷, in 0.01PLC steps.
 AVERAGE READINGS: 1 to 10.
 READING TIME^{1,8,9}: 31ms, typical.

PULSE CURRENT MEASUREMENT OPERATION

TRIGGER LEVEL: 5mA to 5A, in 5mA steps.
 TRIGGER DELAY: 0 to 100ms, in 10μs steps.
 INTERNAL TRIGGER DELAY: 15μs.
 HIGH/LOW/AVERAGE MODE:
 Measurement Aperture Settings: 33.3μs to 833ms, in 33.3μs steps.
 Average Readings: 1 to 100.
 PULSE CURRENT MEASUREMENT ACCURACY¹¹ (2 Years, 23°C ± 5°C):

Aperture	Accuracy ±(% reading + offset + rms noise ¹⁰)
<100 μs	0.2% + 900 μA + 2 mA
100 μs – 200 μs	0.2% + 900 μA + 1.5 mA
200 μs – 500 μs	0.2% + 900 μA + 1 mA
500 μs – <1 PLC	0.2% + 600 μA + 0.8 mA
1 PLC ¹²	0.2% + 400 μA + 0 mA
>1 PLC	0.2% + 400 μA + 100 μA

BURST MODE CURRENT MEASUREMENT

MEASUREMENT APERTURE: 33.3μs.
 CONVERSION RATE: 2040/second, typical.
 INTERNAL TRIGGER DELAY: 15μs.
 NUMBER OF SAMPLES: 1 to 5000.
 TRANSFER SAMPLES ACROSS IEEE BUS IN BINARY MODE: 4800 bytes/s, typical.

LONG INTEGRATION MODE CURRENT MEASUREMENT

MEASUREMENT TIME⁶: 850ms (840ms) to 60 seconds in 1ms steps.

DIGITAL VOLTMETER INPUT (2 Years, 23°C ± 5°C)

INPUT VOLTAGE RANGE: –5 to +30V DC.
 INPUT IMPEDANCE: 2MΩ typical.
 MAXIMUM VOLTAGE (either input terminal) WITH RESPECT TO OUTPUT LOW: –5V, +30V.
 READING ACCURACY¹: ±(0.05% + 3mV).
 READING RESOLUTION: 1mV.
 CONNECTOR: HI and LO input pair part of Output #2's terminal block.
 MEASUREMENT TIME CHOICES: 0.01 to 10PLC⁷, in 0.01PLC steps.
 AVERAGE READINGS: 1 to 10.
 READING TIME^{1,8,9}: 31ms, typical.

NOTES

1. PLC = 1.00.
2. Following 15 minute warm-up, the change in output over 8 hours under ambient temperature, constant load, and line operating conditions.
3. Remote sense, at output terminals, 0.5A to 5A typical.
4. Remote sense, with 4.5m (15 ft) of 16 gauge (1.31mm²) wire and 1Ω resistance in each lead to simulate typical test environment, 1.5A load change (0.15A to 1.65A).
5. Minimum current in constant current mode is 6mA.
6. 60Hz (50Hz).
7. PLC = Power Line Cycle. 1PLC = 16.7ms for 60Hz operation, 20ms for 50Hz operation. Display off.
9. Speed includes measurement and binary data transfer out of GPIB.
10. Typical values, peak-to-peak noise equals 6 times rms noise.
11. Based on settled signal: 100μs pulse trigger delay.
12. Also applies to other apertures that are integer multiples of 1PLC.
13. Recovery to within 20mV of previous level.



Calle del Ebano #16625
 Jardines de Chapultepec
 Tijuana B.C. Mexico
 Tel. (664) 681 1130
 Fax. (664) 681 1150
 Tel. 01800 027-4848
 www.finaltest.com.mx



1.888.KEITHLEY (U.S. only)
 www.keithley.com

A GREATER MEASURE OF CONFIDENCE

Model 2302, 2306, 2306-PJ specifications

SPECIALIZED POWER SUPPLIES