

Model 72993
SMB JACK R/A CRIMP, RG179, 187

Cable Types and Crimp Die Information

Connector Model #	Cable Groups	Crimp Die Cavity Size for Outer Ferrule
72993	RG179, 187	.128 (3.3)

Cable Assembly Instructions

1. CUT CABLE END EVENLY AND PERPENDICULAR

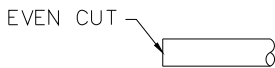

2. SLIDE OUTER FERRULE OVER CABLE END.

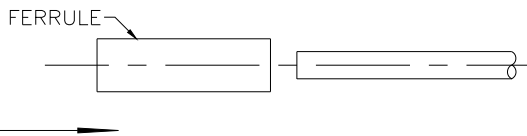

3. STRIP CABLE JACKET, BRAID, AND DIELECTRIC TO SPECIFICATION LENGTHS.

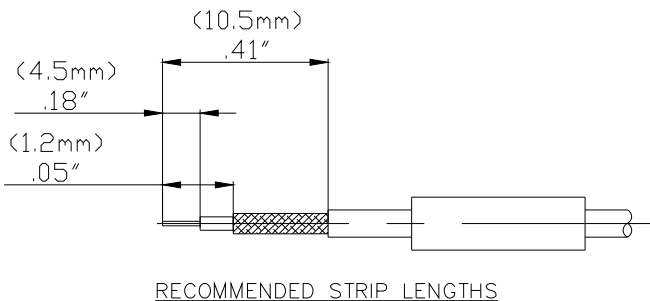

4. FLARE BRAID END SLIGHTLY.

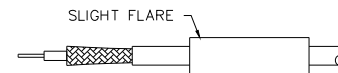

5. SLIDE CONNECTOR BODY OVER CENTER CONDUCTOR.

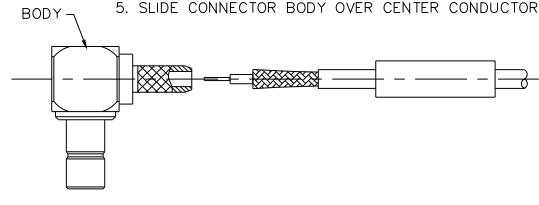

6. SLIDE OUTER FERRULE OVER BRAID AND UP AGAINST BODY ASSEMBLY.

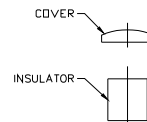
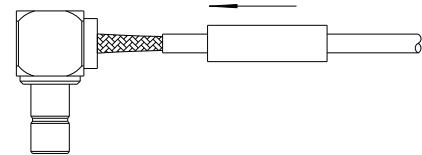

7. CRIMP OUTER FERRULE WITH APPROPRIATE CRIMP TOOL. INSERT INSULATOR INTO CONNECTOR AND PRESS COVER INTO PLACE.

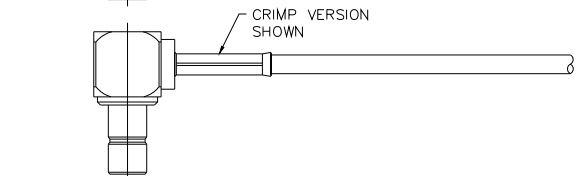

Distribuido Por:
www.finaltest.com.mx
Calle del Eban #16625
Tijuana B.C. Mexico
Tel. (664)681-1130
Tel. 01800 027-4848
ventas@final-test.net



All dimensions are in inches. Tolerances (except noted): .xx = ±.02" (.51 mm), .xxx = ±.005" (.127 mm). All specifications are to the latest revisions. Specifications are subject to change without notice. Registered trademarks are the property of their respective companies.
D2003431 REV 001