



DTX 10 Gig over Copper Test Solution

Certify cabling for 10 Gigabit/sec Ethernet deployments

The DTX 10 Gig over Copper Test Solution, the DTX-1800 CableAnalyzer together with the DTX 10 Gig Kit, enables testing and certification of twisted pair cabling for 10 Gigabit/sec Ethernet deployments. The new 10 Gig performance specification for cabling systems requires more than the certification of each individual cabling link. The 10 Gigabit per second Ethernet technology demands that the crosstalk between wire pairs in adjacent cabling links in bundles be tested and conform to new performance test parameters called Alien Crosstalk (ANEXT and AFEXT). DTX and DTX 10 Gig Kit is the first field test solution that measures performance for 10 Gig and Alien Crosstalk in full compliance with the industry standards to 500 MHz. The DTX 10 Gig over Copper Test Solution follows the DTX CableAnalyzer Series in our commitment to industry-leading performance, accuracy and ease-of-use.

The advantage of the DTX 10 Gig over Copper Test Solution

- The only solution fully compliant with industry standards
- Measures the performance for 10 Gig and Alien Crosstalk in full compliance with the industry standards to 500 MHz
- Simplifies complex Alien Crosstalk link-to-link certification by using the same user-friendly and intuitive DTX interface
- Identifies problematic cable(s) within the same bundle due to link-to-link crosstalk

- Easily calculates the Power Sum Alien Crosstalk test parameters for all the disturber links in the test procedure with included Windows-based DTX AxTalk Analyzer™ software
- Delivers Alien Crosstalk performance test reports to your customers

Overview of the cabling certification process

The certification process for 10 Gig consists of two phases: (1) each individual link needs to be certified for compliance with the cabling link specification for 10 Gig and (2) the Alien Crosstalk performance of the cabling installation needs to be measured and evaluated. Alien Crosstalk is coupling that occurs between wirepairs in different, adjacent cabling links, see Figure 1. Alien Crosstalk is a challenge for twisted-pair cabling as it is the most significant disturbance or noise source for the 10GbE application when using twisted pair cabling.

Certification of individual cabling links

The field certification of installed twisted-pair cabling for 10GBASE-T includes all the test parameters that are currently specified in the TIA/EIA-568-B document for Cat 6. They are Insertion Loss, Return Loss, Pair-to-Pair NEXT, Power Sum NEXT, Pair-to-Pair ELFEXT, Power Sum ELFEXT, Propagation Delay, Length and Delay Skew. The test limits are identical to the limits for Cat 6 up to 250 MHz, but the frequency range and performance requirements for these tests is extended to 500 MHz to support the much higher data rates of the 10Gb/s Ethernet technology.

Use the DTX-1800 CableAnalyzer (DTX 10 Gig Kit not required) to perform the first phase of this field certification process. Verify



the DTX software has been updated to version 1.3 or later. The software updates for the DTX-1800 can be downloaded at no charge from the Fluke Networks' web site. Select the appropriate test standard for 10 Gig in Setup and the tester automatically executes the test procedures for each cabling link over the required frequency range. Exactly as you have always operated this test tool.

Save the test results data in Fluke Networks' LinkWare™ test result management software. These test results will be used during the Alien Crosstalk results evaluation. You are now ready to perform phase 2 – testing Alien Crosstalk.

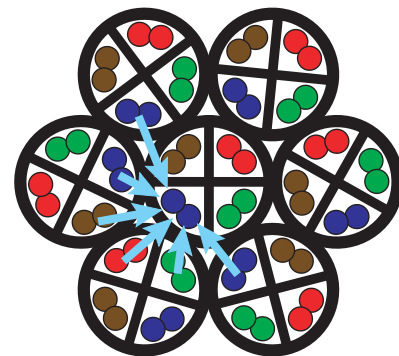

Figure 1: Alien Crosstalk measures the crosstalk signal induced in a wire-pair in the "victim" cable by wire-pairs in adjacent cables (disturber cables) in the bundle or pathway. Alien Crosstalk is defined and measured as Alien NEXT and Alien FEXT.

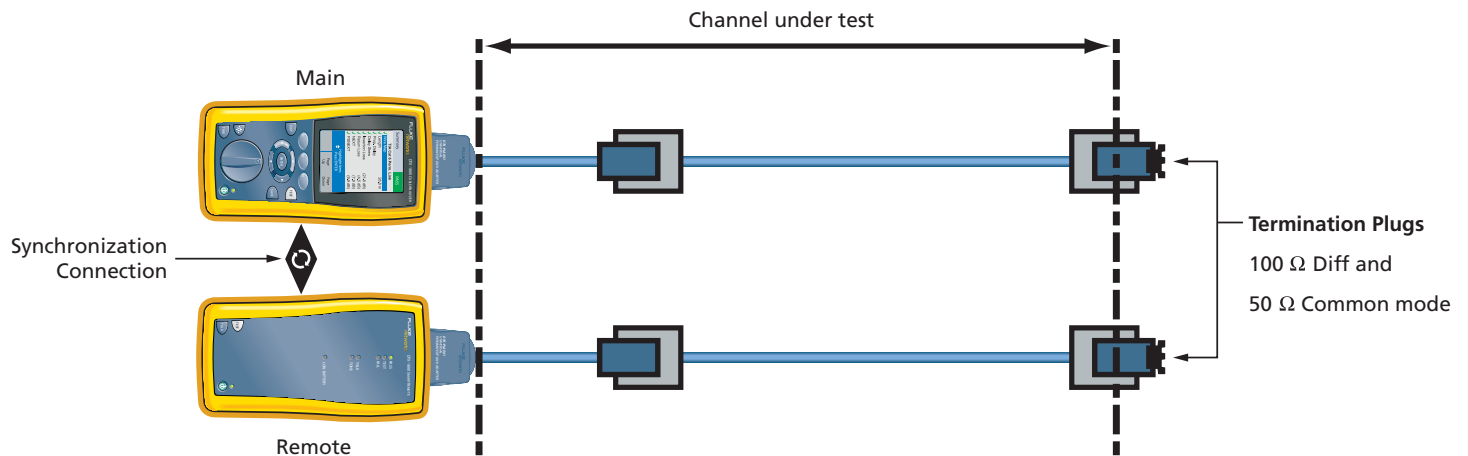

Figure 2: Pair-to-pair Alien NEXT measurements. The main and remote units are sitting side-by-side at one end of the cabling bundle under test. These units are plugged into different cables. The Alien Crosstalk Communication Modules plugged into the main and smart remote units are connected with a patch cord to provide the measurement synchronization that allows the testers to perform all of the pair-to-pair Alien NEXT measurements.

Certification for Alien Crosstalk compliance

The test procedures for Alien Crosstalk (AXTalk) parameters require a DTX-1800 with the hardware and software provided in the DTX 10 Gig Kit. This kit includes:

- a) Communication Modules plugged into the back cavity in the DTX-1800 Main and Remote units
- b) Channel Adapters optimized for Alien Crosstalk testing
- c) Permanent Link Adapters optimized to test and certify Cat 6A / Class E_A permanent links
- d) Link Terminators that provide differential and common mode termination for high-frequency testing
- e) Windows-based software that stores all the measured test results between individual cabling links and calculates the Power Sum Alien Crosstalk test parameters for all the disturber links in the test procedure

The setup for an Alien NEXT measurement between two links is shown in Figure 2. The Main DTX-1800 unit plugs into the disturbed cabling link (the victim link) and the Remote unit is plugged into a disturber link. The two test units measure the Alien Near-End Crosstalk between all the wire pairs of the two cabling links in approximately 25 seconds. Note that the Alien Crosstalk communication modules must be installed in each tester unit and that these two modules must be connected with a patch cord. Also, the two cables in the test procedure must be terminated with the special Link Terminators. The DTX 10 Gig Kit contains two Link Terminators. Additional modules can be purchased to save time.

The Main tester is to be connected to a Windows-based PC or laptop computer running the DTX AxTalk Analyzer™ program using a USB cable. The DTX AxTalk Analyzer program controls the tests and automatically uploads the alien crosstalk measurement results between all the wire-pairs of the two measured links. After the test results of the first disturber link have been uploaded, you are ready to add data from other disturber links. The Main unit remains connected to the victim (disturbed) link while the remote unit is connected to the next disturber to be included in the Alien Crosstalk evaluation. Upon completion of the Alien Crosstalk measurements between the victim and a disturber link, the AxTalk Analyzer program uploads all the pair-to-pair test results and automatically calculates the Power Sum Alien Crosstalk test parameters for the victim link.

The contribution of additional disturber links are measured and added until all links in the bundle of the victim link have been included in the test. The AxTalk Analyzer program shows the calculated value of the final Power Sum test parameters and issues a Pass or Fail result. The setup to measure the Power Sum Alien FEXT test results is similar and requires the tester connection as shown in Figure 3. Note you need a cabling link not included in the list of disturber links to provide the connection between the Communication Modules in the testers.

When testing Alien FEXT in horizontal cabling, often you will not have access to an extra link to establish communication between the test units. The Alien Crosstalk Communication Module can also be used to terminate a link and to establish the communication between the

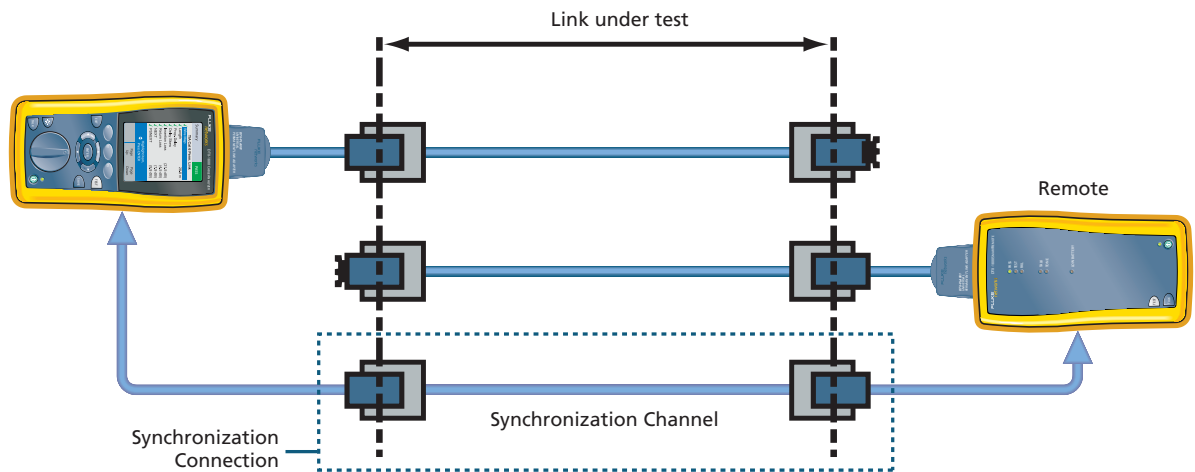

Figure 3: Pair-to-pair Alien FEXT measurements. The main and remote units are plugged into different cabling links at opposite ends of bundle under test. A spare channel in this bundle connects the synchronization modules plugged into each of the testers to allow the testers to perform all of the pair-to-pair FEXT measurements between the wire pairs of two selected cabling links.

two tester units. Rather than using the Link Terminators, connect a patch cord to the end of the disturber and disturbed link; plug these patch cords into the Alien Crosstalk Communication Modules of the adjacent test unit as shown in Figure 4.

For an in-depth overview of the developments of the 10GBASE-T Standards, including an overview of cabling types, best practices for design and installation, a technical look at Alien Crosstalk and to download technical white-papers, visit our 10 Gig Resource Center: www.flukenetworks.com/10gig

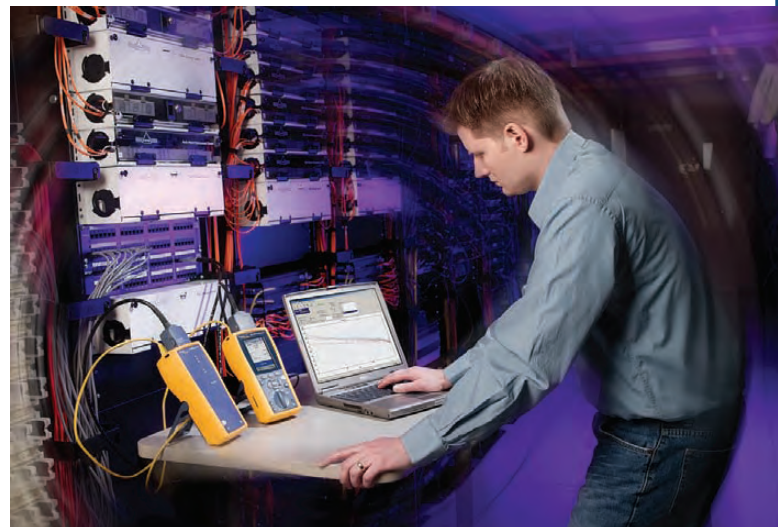

Figure 4: Alternate method for Alien FEXT measurement when testing horizontal cabling and a separate communication link is not available.



Ordering information

Model	Description
DTX-10GKIT	<p>Alien Crosstalk Analyzer Kit for DTX-1800</p> <p><i>This kit includes:</i></p> <ul style="list-style-type: none"> • Two DTX-AXTLK1 Communication Modules • Windows based DTX AxTalk Analyzer™ Software • Two Cat 6A/Class E_A Permanent Link Adapters (DTX-PLA002S) • Two Channel Adapters optimized for Alien Crosstalk measurements to 500 MHz (DTXCHA001AS) • Two Link Terminators (DTX-AXTERM) • Two RJ45-to-RJ45 Couplers



NETWORK SUPERVISION

Fluke Networks
P.O. Box 777, Everett, WA USA 98206-0777

Fluke Networks operates in more than 50 countries worldwide. To find your local office contact details, go to www.flukenetworks.com/contact.

©2006 Fluke Corporation. All rights reserved.
Printed in U.S.A. 8/2006 2669770 D-ENG-N Rev A