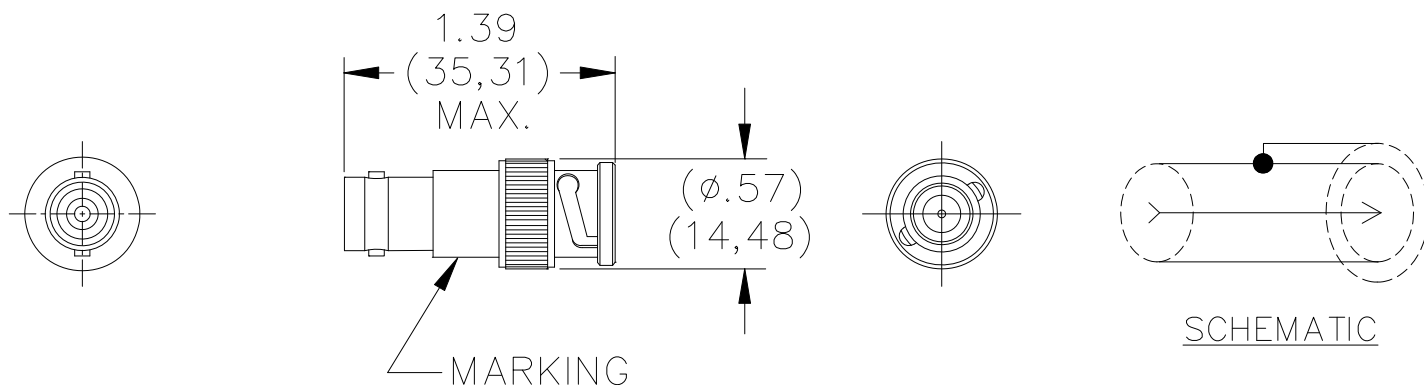

Model 5090
BNC (F) to 2 Lug Triaxial (M) Adapter

Features

- Provides an easy interface between a BNC (F) and a 2 Lug Triax (M).

Materials

Body: Brass, Tarnish Resistant Nickel Plated
Dielectric: PTFE per L-P-403
Center Contact: Male – Brass, Gold Plated
Female – Beryllium Copper, Gold Plated
Outer Contact: Beryllium Copper, Tarnish Resistant
Marking: "POMONA 5090" (optional)



Specifications

Operating Voltage: For CE compliance: not intended for hand-held use at voltages above 33 Vrms/70 Vdc.
Frequency Range: DC to 500 MHz

Ordering Information

Model: 5090

Distribuido Por:
www.finaltest.com.mx
Calle del Ebanó #16625
Tijuana B.C. Mexico
Tel. (664)681-1130
Tel. 01800 027-4848
ventas@final-test.net

FINAL TEST^{MR}
Venta de Instrumentos de Prueba y Medición

All dimensions are in inches. Tolerances (except noted): .xx = \pm .02" (.51 mm),
.xxx = \pm .005" (.127 mm). All specifications are to the latest revisions.
Specifications are subject to change without notice. Registered trademarks are
the property of their respective companies.