

# Pomona®

## Model 5203 Die Cast Box With Card Guides Size L, Unpainted

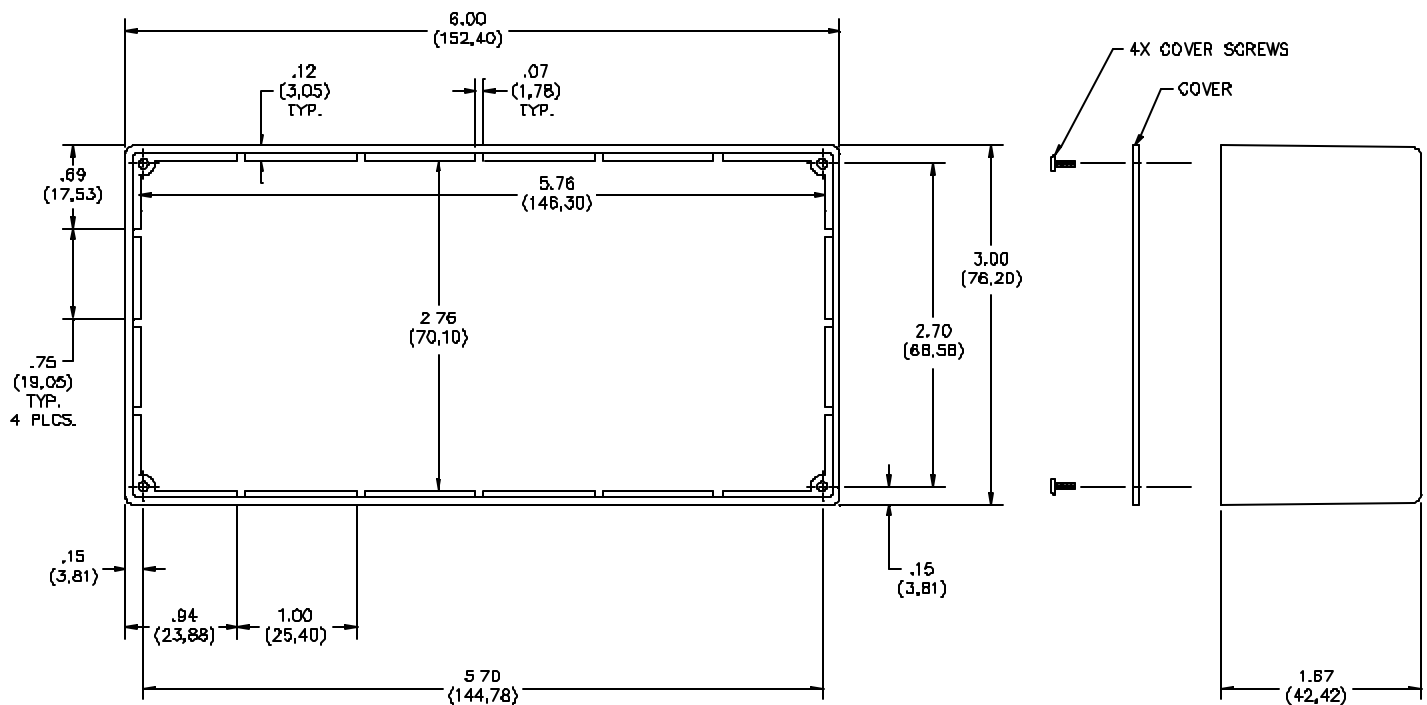

### MATERIALS:

#### Die Cast Box:

Aluminum die cast, Alloy A380 or A384

Finish: None

Marking: "POMONA ELECTRONICS, CALIF."

#### Cover:

1.60 mm (.063) thick aluminum Alloy 1100-H14

Finish: Clear anodized

Marking: None

#### Screws:

4 each, 2-32 X 6.35 MM (.25) long Pan Head, self-tapping

Steel

Finish: Nickel Plated

### RATINGS:

Operating Temperature: -55° C. to +150° C. (-67° F. to +302° F.)

### ORDERING INFORMATION: Model 5203

All dimensions are in inches. Tolerances (except noted): .xx = ±.02" (.51 mm), .xxx = ±.005" (.127 mm).

All specifications are to the latest revisions. Specifications are subject to change without notice.

Registered trademarks are the property of their respective companies. Made in USA

Distribuido Por:

www.finaltest.com.mx

Calle del Ebanó #16625

Tijuana B.C. Mexico

Tel. (664)681-1130

Tel. 01800 027-4848

ventas@final-test.net

**FINAL TEST**<sup>MR</sup>  
Venta de Instrumentos de Prueba y Medición