

# Operating Instructions



## HVT-HD Series

**Digital Series  
High Duty-Cycle  
AC Hipot**

Version 1.0



## **WARNING**

**Before operating the instrument, be sure to read and fully understand the operating instructions. This instrument produces hazardous voltages. It is the responsibility of the user to ensure that the system is operated in a safe manner.**



**This equipment contains exposed terminals carrying hazardous voltages. There are no user serviceable components in the unit. All repairs and upgrades that require the unit to be opened must be referred to HIPOTRONICS or one of their nominated agents.**

HIPOTRONICS and its sales partners refuse to accept any responsibility for consequential or direct damage to persons and/or goods due to the lack of observance of instructions contained herein or due to incorrect use of the equipment.

Further be aware that safety is the responsibility of the user!

Any correspondence regarding this instrument should include the exact type number, instrument serial number and firmware version number. With the exception of the firmware version number, this information can be found on the registration plate on the right panel of the instrument. The firmware version can be found in the bottom right corner of the settings window.

Unauthorized opening of the unit may damage the EMI protection of the system and will reduce its resistance to interference and transients. It may also cause the individual unit to be no longer compliant with the relevant EMC emission and susceptibility requirements. If the unit has been opened, the calibration will be rendered invalid and the warranty will be void.

### Note

HIPOTRONICS has a policy of continuing improvement on all their products. The design of this instrument will be subject to review and modification over its life. There may be small discrepancies between the manual and the operation of the instrument, particularly where software has been upgraded in the field.

HIPOTRONICS retains the right to modify the functionality, specification or operation of the instrument without prior notice.

© All rights reserved. No section of this manual may be reproduced in any form, mechanical or electronic without the prior written permission of HIPOTRONICS.

## Manual Conventions

In the manual, the following conventions are used:



Indicates a matter of note.

If it refers to a sequence of operations, failure to follow the instructions could result in errors in measurement.



Indicates hazards.

There is a risk of equipment damage or personal injury or death. Carefully read and follow the instructions. Be sure to follow any safety instructions given in addition to those for the site at which tests are being performed.

# Foreword

Welcome, new user of the “HVT Series”. Thank you for placing your confidence in our product.

With the purchase of this measuring instrument you have opted for all the advantages that have built a world-wide reputation for a HIPOTRONICS Instrument: robustness, performance and quality. As a result, this instrument provides a solution which achieves the optimal combination of traditional know-how and leading edge technology.

This operating manual is designed for completeness and easy location of the required information. Customers who already have experience with this kind of equipment will find this document to be of assistance as an extended help.

If you find a mistake or inconsistency in the operating manual then please feel free to inform our Customer Support department with your corrections so that other users may benefit.

# Contents

<b>1</b>	<b>Introduction</b>	<b>4</b>
1.1	Receiving Instructions .....	4
1.2	General .....	4
1.3	Scope of Supply .....	5
1.3.1	Standard Scope of Supply .....	5
1.3.2	Options and Accessories .....	6
1.4	Technical Data: HVT-HD .....	7
1.4.1	Physical and Environmental Specifications .....	7
1.4.2	Measurement .....	7
<b>2</b>	<b>Safety</b>	<b>8</b>
2.1	General .....	8
2.2	Essential Safety Recommendations .....	9
2.3	Interlock connection .....	9
2.4	Summary .....	9
<b>3</b>	<b>Theory</b>	<b>10</b>
3.0	Introduction .....	10
3.1	Test Standards .....	10
3.2	HV Output Rating .....	10
3.3	Load / DUT Types .....	11
3.3.1	Bucket Trucks .....	11
3.3.2	Switch Gear, Vacuum Bottles, and Interrupters .....	14
3.3.3	Hot Sticks, Gloves, and Ropes, Hydraulic Hoses .....	15
<b>4</b>	<b>Front Panel</b>	<b>16</b>
<b>5</b>	<b>Connection and Setup</b>	<b>17</b>
5.1	Guard/Ground/Return Connections .....	17
5.1.1	INTERNAL SWITCH BETWEEN GROUND AND RETURN .....	17
5.1.2	INTERNAL SWITCH BETWEEN GROUND AND GUARD .....	18
5.2	Connecting the Instrument .....	20
<b>6</b>	<b>Software</b>	<b>21</b>
6.1	Startup & Main Menu .....	21
6.2	Test Modes .....	22
6.3	Settings .....	26
6.4	Test Reports .....	27
6.5	HIPODirect .....	29
<b>7</b>	<b>Troubleshooting</b>	<b>30</b>
7.1	Diagnostics .....	30

7.2	Warning and Error Messages .....	31
<b>8</b>	<b>Miscellaneous</b>	<b>32</b>
8.1	Care and Maintenance.....	32
8.1.1	Cleaning the Instrument .....	32
8.1.2	Instrument Calibration .....	32
8.1.3	Changing Fuses .....	32
8.2	Instrument Storage .....	32
8.3	Packing and Transport.....	33
8.4	Recycling .....	33
<b>9</b>	<b>Customer Support</b>	<b>34</b>
9.1	Declaration of Conformity.....	35
	Hipotronics, Inc. ....	35
9.2	Warranty .....	36

# 1 Introduction

---

## 1.1 Receiving Instructions

When received, any possible transport damage should be noted. A written record should be made of any damage. A suitable remark should be recorded on the delivery documents.

A claim for damage must be reported immediately to the transport company and to the Customer Support Department of HIPOTRONICS or the local agent. It is essential to retain the damaged packing material until the claim has been settled.

Check the contents of the shipment for completeness immediately after receipt (See chapter “Scope of Supply”). If the shipment is incomplete or damaged, then this must be reported immediately to the transport company and the Customer Support Department of HIPOTRONICS or the local agent. Repair or replacement of the instrument can then be organised immediately.

---

## 1.2 General

The HVT-HD Series digital AC Hipot is a modern solution for testing insulation strength of electrical apparatus. Outfitted with state-of-the-art digital interface and extensive safety features, the HVT-HD series ensures simplistic operation, the most accurate results, and operator safety under all circumstances. The HVT-HD series meets ANSI/SIA A92.2, ANSI C37.20, IEC 62271-200, ASTM specifications.

Accurate voltage and current measurements are measured via voltage readings that are taken directly at the output of the high voltage transformer bonnet and current leakage current measurements are taken in the return leg.

---

## 1.3 Scope of Supply

### 1.3.1 Standard Scope of Supply

The following items are supplied with the standard instrument:

Qty	Description
1	HVT controller
1	HVT HV section w/ interconnect cable
1	Protective earth ground cable
1	VM measurement probe and cable (Standard with 100kV units)
1	Return measurement cable with connecting clamp
1	Interlock plug (Part Number: HH145983)
1	Power input cable (Region Specific)
1	Calibration Certificate

Once the unit has been received, check that all items have been delivered. Also check that the correct power cord for your location has been supplied. In the event of missing or damaged parts please contact your local sales representative stating the serial number and type of the instrument and the sales order number.

### 1.3.2 Options and Accessories

Part Number	Description	Image
HH-700-HS	Hand-Operated Interlock Switch	 A hand-operated interlock switch with a blue handle and a black cable ending in a connector.
HH-700-FS	Foot-Operated Interlock Switch	 A yellow foot-operated interlock switch with a black foot pedal.
HH-WARN-HV	Safety Strobe Light with Magnetic Base	 A red safety strobe light with a white and black magnetic base.
HH-VMP60 / HH-VMP120	60/120 kV Rated Voltmeter Probe	 A blue voltmeter probe with a black braided lead and a hook at the end.
HHDA13-280	Grounding Stick with 25ft braided lead, rated to 120kV	 A green grounding stick with a black braided lead and a hook at the end, being held by a gloved hand.

# 1.4 Technical Data: HVT-HD

## 1.4.1 Physical and Environmental Specifications

Mains	90-264 VAC 50/60Hz
Frequency Output	50Hz or 60Hz
Operating temperature	14...122° F (-10 .. 50°C)
Storage temperature	-4...158° F (-20 .. 70°C)
Humidity	5 .. 95 % r.h. non-condensing
Dimensions (W x D x H)	Controller: 16.6" x 7.75" x 20.5" (42.2 x 19.7 x 52.0cm) 100kV Bonnet: 17 x 14 x 32 in (44 x 37 x 81 cm)
Weight	Controller: 35lbs (15.9kg) 100kV Bonnet: 135lbs (61.2kg)

## 1.4.2 Measurement

Output	
Voltage	100kV Bonnet: 1kV...100kVACrms
Current	100kV Bonnet: 50mA (100kV Tap), 100mA (50kV Tap)
Duty Cycle	0-2.5KVA: 1/hr/1hr ON/OFF 2.5-5KVA: 15min/1hr ON/OFF
Measurements	
Voltage	Accuracy: +/- 1.5% of Reading +/- 0.2% F.S. Resolution: 0.1KV
Current	Ground- Guard Mode (UST) 0... 1000uA, 0.1mA... 100mA (Two auto-ranges) Accuracy: +/- 1.5% of Reading +/- 0.2% F.S.
	Ground-Return Mode (GST) 0... 1000uA, 0.1mA... 100mA (Two auto-ranges) Accuracy: 2% full scale
Phase Angle	+/- 10°

# 2 Safety



**Remember:  
Hazardous voltage can shock, burn or cause death !**



The unit should only be operated after carefully reading the user manual which is an integral part of the instrument.

HIPOTRONICS and its sales partners refuse to accept any responsibility for consequential or direct damage to persons and/or goods due to non observance of instructions contained herein or due to incorrect use of the equipment.

Further be aware that Safety is the responsibility of the user!

---

## 2.1 General

Safety is the most important aspect when working on or around high voltage electrical equipment.

Personnel whose working responsibilities involve testing and maintenance of the various types of high voltage equipment must have understood the safety rules written in this document and the associated safety practices specified by their company and government. Local and state safety procedures should also be consulted. Company, regional or national regulations must be fulfilled beyond HIPOTRONICS recommendations.

If the instrument is damaged or it is possible that damage has occurred, for example during transportation, do not apply any voltage. The instrument may only be used under dry operating conditions.

Do not open the unit; it contains no user replaceable parts.

People with heart pacemakers should not be in the vicinity of this system during operation.



Safety is the responsibility of the user. Always operate the equipment in accordance with the instructions, always paying full attention to local safety practices and procedures.



This equipment must be operated only by trained and competent personnel who are aware of the dangers and hazards involved in testing transformers.



Do not operate the HVT from a variable power supply. The HVT adjusts to the local line voltage at start-up. Changing the line voltage while the unit is in operation may cause damage to the unit and to the test object

---

## 2.2 Essential Safety Recommendations



Before connecting the instrument ensure that the transformer to be tested is completely de-energized and isolated from both line and load. Every terminal should be checked and verified before connection of the instrument. Ground connections may be left in place.



Never exchange connections to the HV and LV sides of the transformer. The red connections must always be connected to the High Voltage side of the transformer. The black connections must always be connected to the Low Voltage side of the transformer. Interchanging any or all of the connections may result in damage to the transformer or the instrument and represents a significant safety hazard for personnel.



Never operate the equipment in an explosive environment or where there are flammable gases or fumes



The instrument must always be connected to a grounded power outlet (i.e. a safety earth). It must never be operated in a non-grounded configuration as this may result in electrical shock to the user or damage to the instrument.

---

## 2.3 Interlock connection



The Interlock connection allows for safe operation of the system, allowing exclusive control to the operator for system and HV operation. Control of the interlock connection is provided by three primary accessories:

1. Interlock plug (Included accessory)
2. Hand-operated interlock switch, HH-700-HS ( Optional accessory)
3. Foot-operated interlock switch, HH-700-FS ( Optional accessory)

---

## 2.4 Summary

Note: Many accidents that happen around high voltage equipment involve personnel who are familiar, and perhaps too familiar, with high voltage equipment. Staying alert and ever watchful requires constant training and awareness of the inherent hazards. The greatest hazard is the possibility of getting on a live circuit. To avoid this requires constant vigilance - for oneself and for one's fellow workers.

In addition to the obvious dangers, personnel should be alert to recognize subtle dangers as well. For example, during a routine hipot, the HV Output may have significant voltages induced in them by simple transformer action. Therefore, **all terminals of a device under test, unless grounded, should be considered to be live while the test is in progress.**

**Remember: Safety, FIRST, LAST, and ALWAYS !**

# 3 Theory

---

## 3.0 Introduction

### 3.1 Test Standards

- NETA MTS 2015: Maintenance Test Specifications 2015
- IEEE 4-2013: IEEE Standard for High-Voltage Testing Techniques
- IEC60060-3 ed1.0: High-Voltage Test Techniques: On-site Testing
- ANSI 92.2: Vehicle- Mounted Elevating and Rotating Aerial Devices

---

### 3.2 HV Output Rating

100HVT-HD:	50kV Tap	100mA
	100kV	50mA

## 3.3 Load / DUT Types

### 3.3.1 Bucket Trucks

#### 3.3.1.1 ANSI Test on Upper Insulated Arm of a Double Insulated Boom Truck

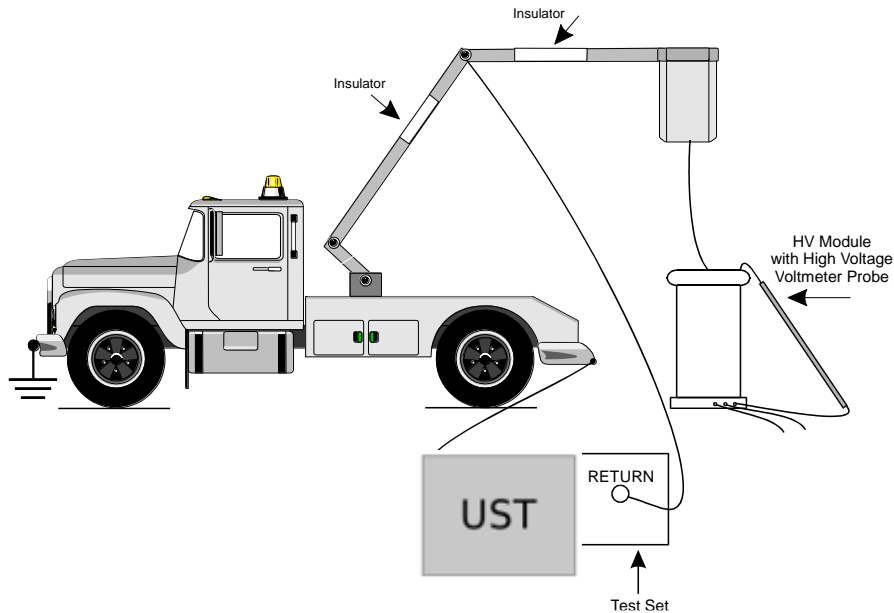

#### 3.3.1.2 ANSI Test on the Upper Arm of a Single Insulated Boom Truck

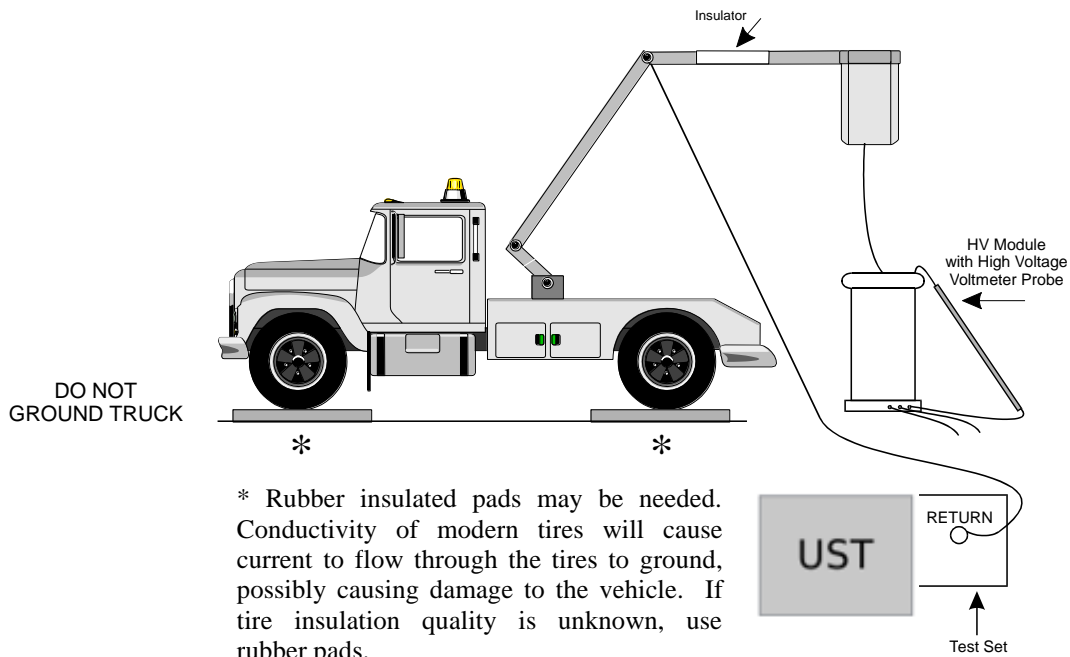

### 3.3.1.3 Flashover Test on Lower Insulated Arm of Double Insulated Boom Truck

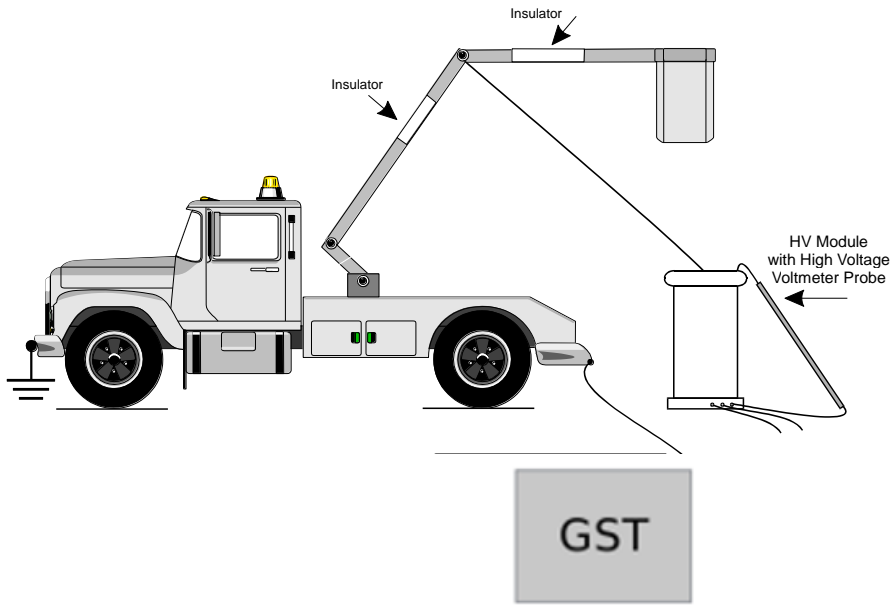

### 3.3.1.4 Overall Test on Double Insulated Boom Truck

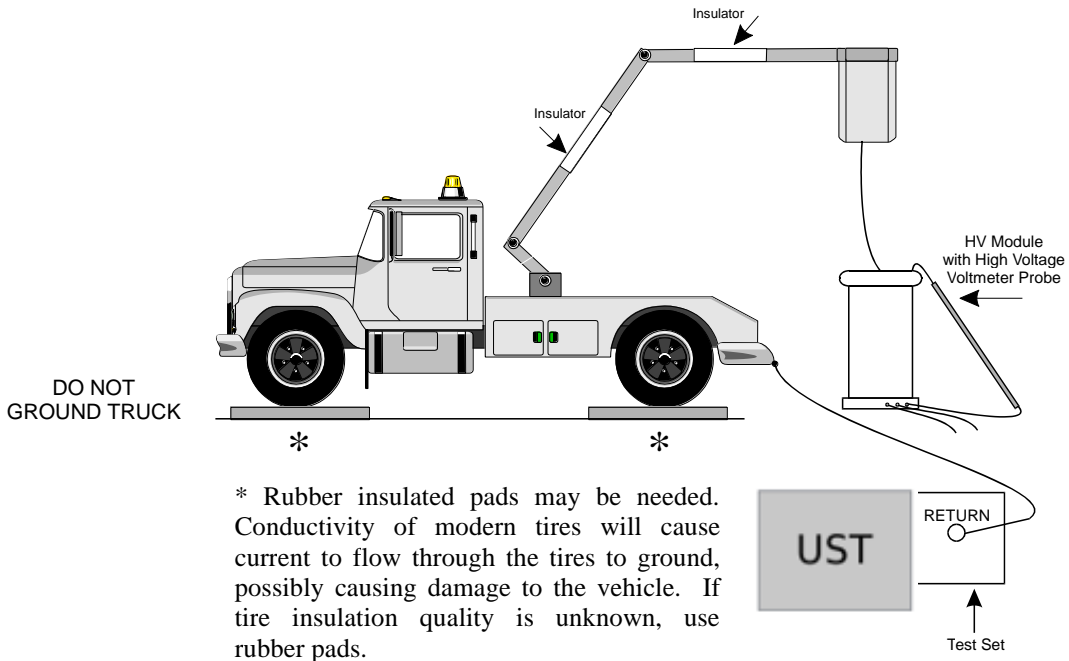

### 3.3.1.5 Phase-to-Phase Test on Double Insulated Boom Truck

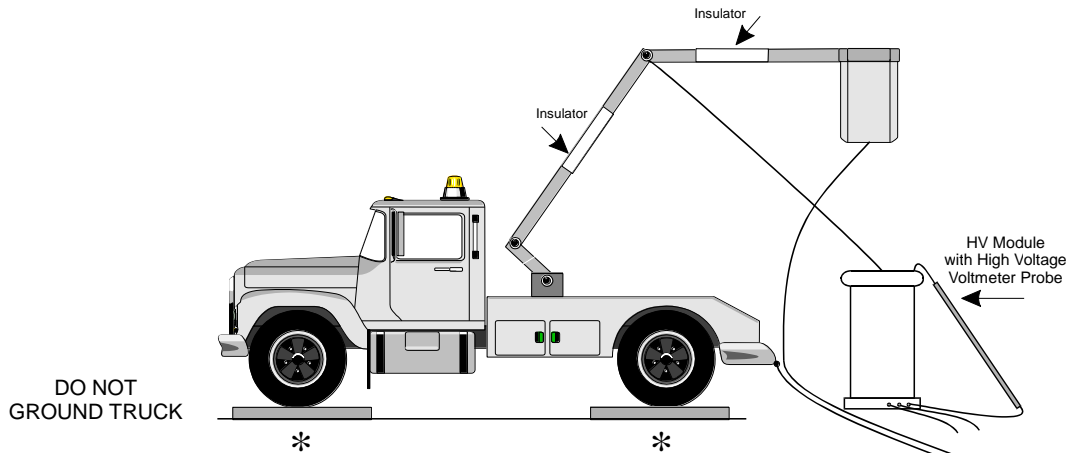

\* Rubber insulated pads may be needed. Conductivity of modern tires will cause current to flow through the tires to ground, possibly causing damage to the vehicle. If tire insulation quality is unknown, use rubber pads.

### 3.3.1.6 Flashover Test on Bucket Liner in Water

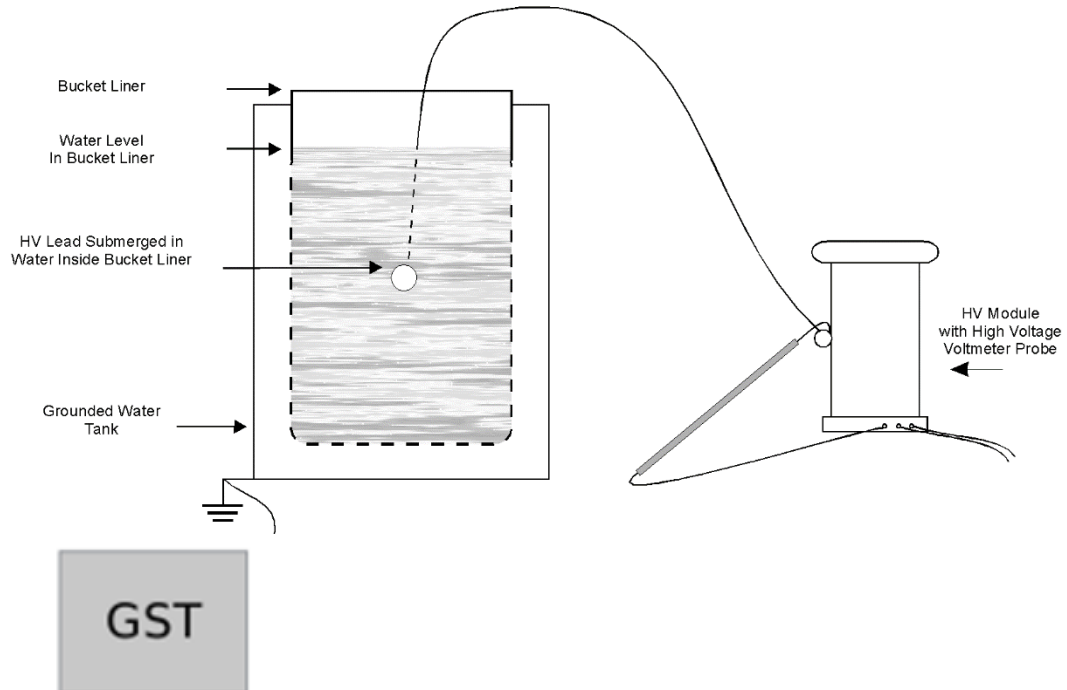

### 3.3.2 Switch Gear, Vacuum Bottles, and Interrupters

#### 3.3.2.1 Switch Gear Withstand Tests (NETA MTS 2015)

Switchgear Withstand Test Voltages

Type of Switchgear	Rated Maximum Voltage (kV) (rms)	Maximum Test Voltage (kV)	
		AC	DC
Low-Voltage Power Circuit Breaker Switchgear	.254/.508/.635	1.6	2.3
Metal-Clad Switchgear	4.76	14	20
	8.25	27	37
	15	27	37
	27	45	a
	38	60	a
Station-Type Cubicle Switchgear	15.5	37	a
	38	60	a
	72.5	120	a
Metal-Enclosed Interrupter Switchgear	4.76	14	20
	8.25	19	27
	15	27	37
	27	45	a
	38	60	a

#### 3.3.2.2 Interrupter Withstand Tests (NETA MTS 2015)

Nominal Voltage Class (kV)	Maximum Voltage (kV)	Rated Impulse Withstand Voltage (kV)	Maximum AC Field Test Voltage (kV)
14.4 (1 $\phi$ and 3 $\phi$ )	15	95	26.2
14.4 (1 $\phi$ and 3 $\phi$ )	15.5	110	37.5
24.9 (1 $\phi$ and 3 $\phi$ )	27	150	45
34.5 (1 $\phi$ and 3 $\phi$ )	38	150	52.5
46.0 (3 $\phi$ )	48.3	250	78.7
69 (3 $\phi$ )	72.5	350	120

### 3.3.3 Hot Sticks, Gloves, and Ropes, Hydraulic Hoses

#### 3.3.3.1 Class Table

Class of Equipment	Max Voltage Use (AC)	Proof Tested (VAC)
00	500	2,500
0	1,000	5,000
1	7,500	10,000
2	17,000	20,000
3	26,500	30,000
4	36,000	40,000

# 4 Front Panel

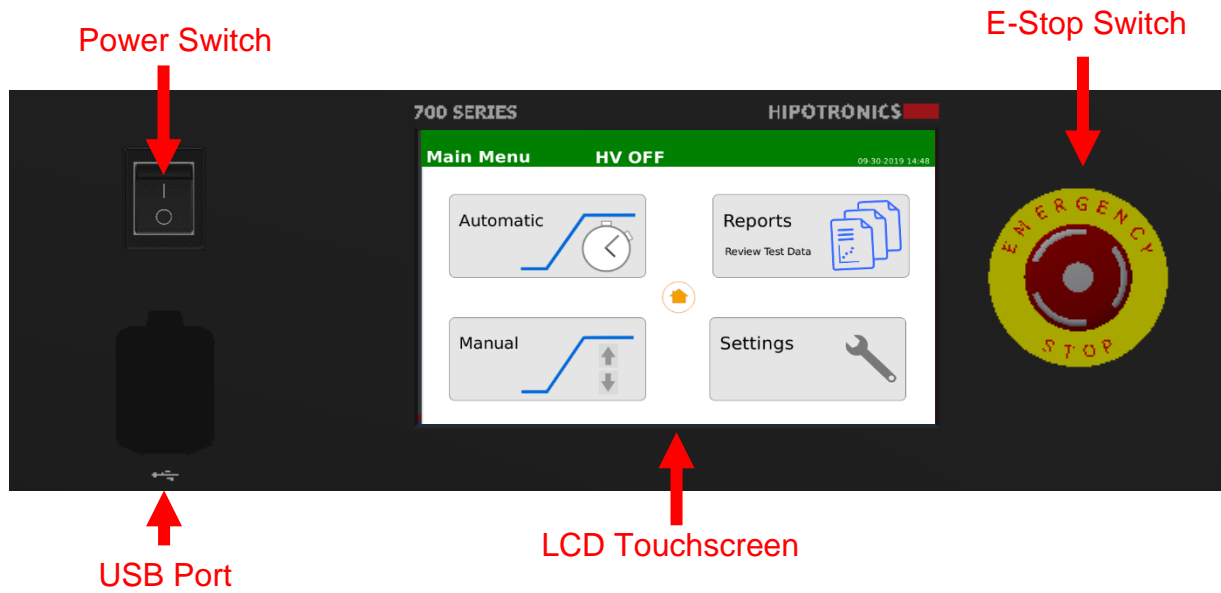

**Power Switch:** Toggle unit power on/off

**USB Port:** Insert USB Drive, formatted to FAT32, when exporting test reports

**LCD Touchscreen:** Display and User-Interface

**E-Stop Switch:** Pressing this button will interrupt the main high voltage contactors, causing the HV circuit to be deenergized within milliseconds

# 5 Connection and Setup

---

## 5.1 Guard/Ground/Return Connections

The return current connection on the user interface provides current measurement of the test sample. This connection is internally referenced or guarded with respect to ground. **Figure 3** and **Figure 4** illustrate these internal connections.

### 5.1.1 INTERNAL SWITCH BETWEEN GROUND AND RETURN

When RETURN is selected, all current is presented to the internal current meter. This mode of operation should be used only when extremely sensitive measurements are unnecessary or when a test specimen must be grounded. Note that no connection to GUARD is necessary.

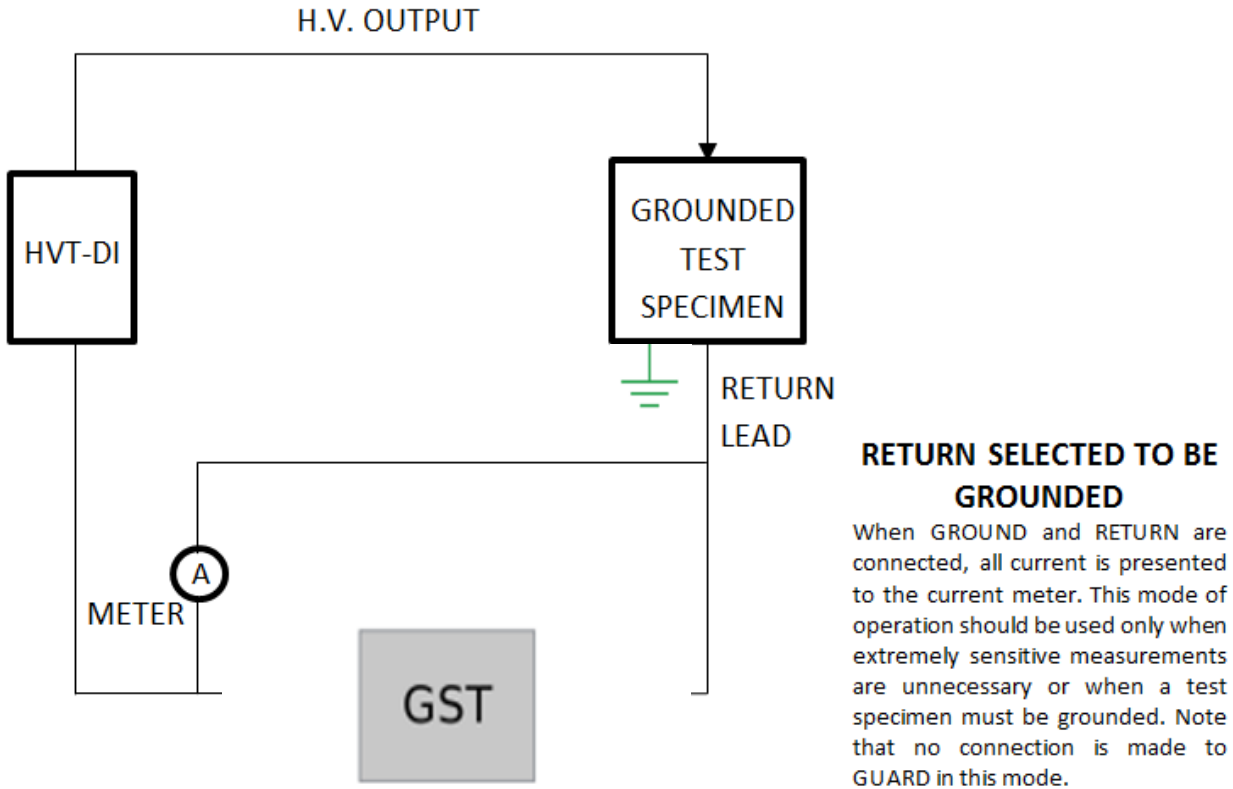

**Figure 3** *Internal Link Connected Between Ground and Return*

### 5.1.2 INTERNAL SWITCH BETWEEN GROUND AND GUARD

The sole function of this mode of operation is to separate the paths of leakage currents. These leakage currents are *leakage to ground* and *leakage across the test specimen*. The leakage currents to **GROUND** are bypassed around the current meter, measuring only the specimen leakage current. The low side (**RETURN**) connection of the specimen must be "floated" (isolated from **GROUND**). This mode of operation should be used only when extremely sensitive measurements are desired.

This is typically used for discrete components or when leakage to **GROUND** is to be disregarded. For example, when testing a transformer for leakage (or resistance) between the secondary and the primary, the guarded return mode allows leakage to the core or frame to bypass the meter, thus reading only leakage between the two coils.

It is not possible to test installed cables in this mode of operation, as the cable shields are always grounded, making it impossible to see the leakage current.

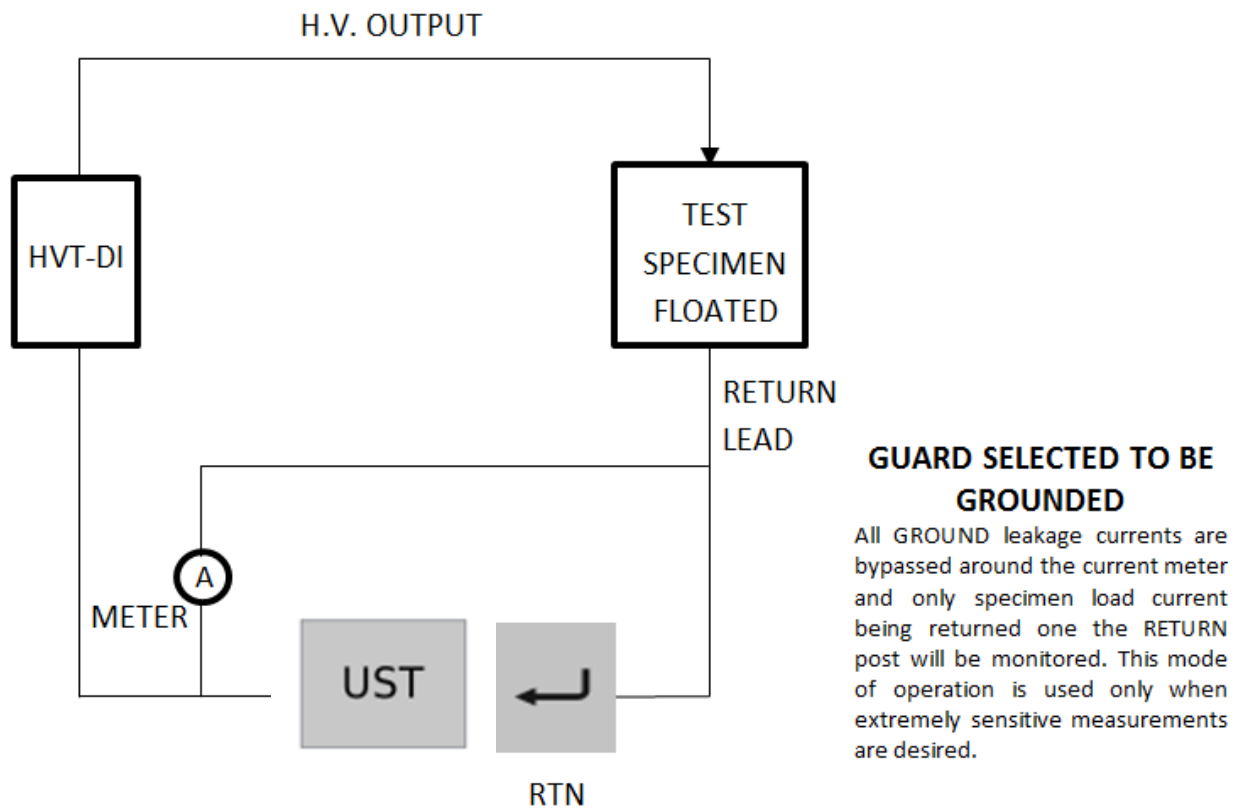

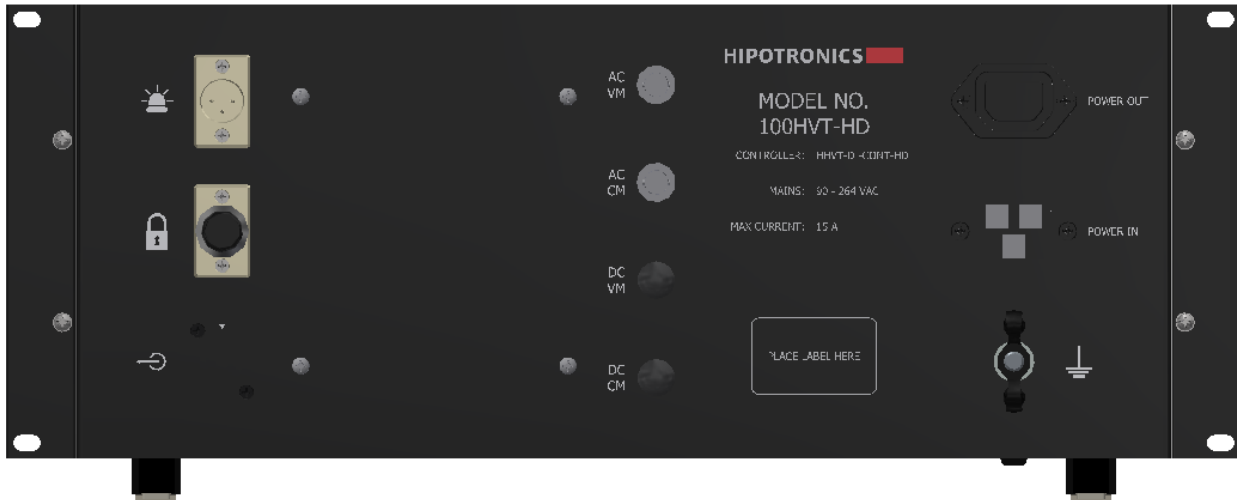

**Figure 4** *Internal Link Connected Between Ground and Guard Post*

## 5.2 Connecting the Instrument



To properly connect the HVT-DI AC Hipot Controller, please follow the instructions below:

- Connect Ground Cable to Controller post (  ) and Earth Ground.
- Connect the interconnect cable to the black port on the Controller (  ).
- Connect the BNC plug on the interconnect cable to the BNC-terminal labeled return (**RTN**) on the HV-bonnet-base.
- Hook the VM Probe to the toroid as above and connect the other end to the terminal on the HV-bonnet-base labeled "HV Probe" using the shorter BNC cable. Connect the VM terminal on the HV-bonnet-base (**VM**) to the AC VM BNC port on the controller with the provided BNC cable.
- Connect the current probe alligator clip to the DUT and connect the BNC plug on the other end to the AC CM BNC port on the controller.
- Connect the top of the HV-bonnet to the DUT using customer-supplied output connection.
- Insert provided interlock plug into port on controller (  ).
- Once all the connections have been made, connect the power cord to the controller and power on.

# 6 Software

## 6.1 Startup & Main Menu

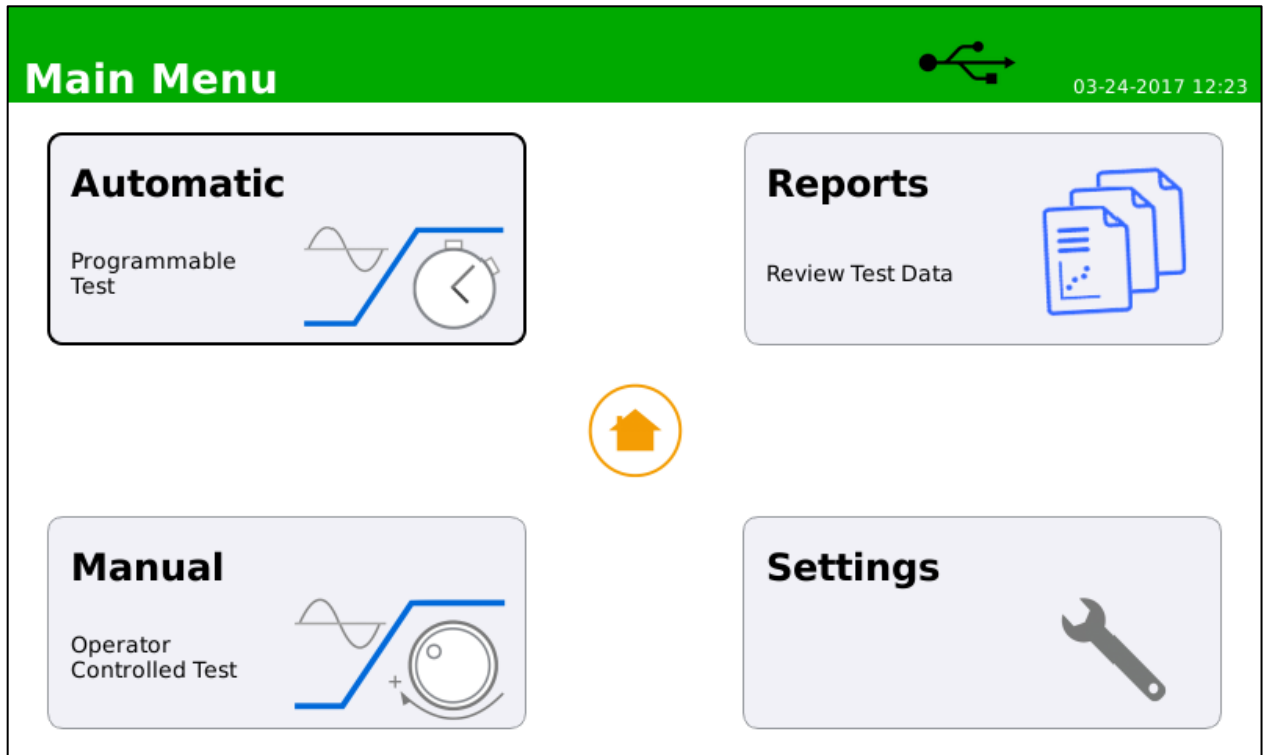

The home window includes options to access the screens for automatic testing mode, manual testing mode, viewing previously saved reports, and viewing or adjusting the system settings.

The top bar will indicate what window you are currently in, whether High Voltage is on or off, whether a USB device is connected, the date/time, and the internal temperature in the testing screens. When the top bar is green, there is no High Voltage present on the output; and when the top bar turns red, the unit is outputting High Voltage.

## 6.2 Test Modes

### Manual Mode Operation Interface with HV OFF

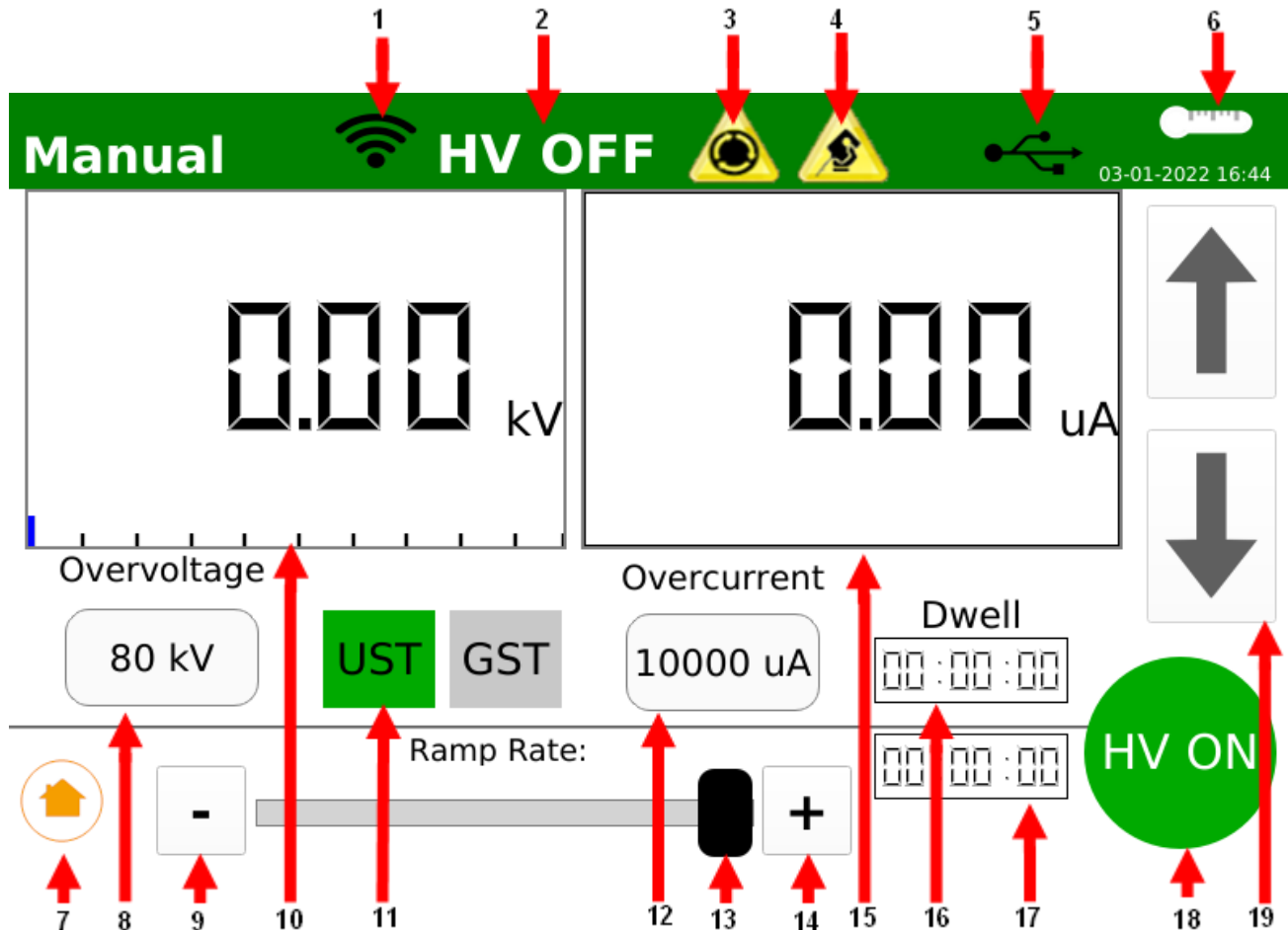

- 1 – WiFi Connected Indicator
- 2 – High Voltage Indicator
- 3 – Emergency Stop Engaged
- 4 – External Interlock Open
- 5 – USB Drive Detected
- 6 – Internal Temperature Monitor
- 7 – Return to Main Menu
- 8 – Overvoltage, Touch to Set
- 9 – Decrease Ramp Speed of Up/Down Buttons

- 10 – Volt Meter Display, Touch to Toggle Analog/Digital
- 11 – Ungrounded-Specimen or Grounded-Specimen Selection
- 12 – Overcurrent, Touch to Set
- 13 – Ramp Speed Slider
- 14 – Increase Ramp Speed of Raise/Lower Buttons
- 15 – Current Meter, Touch to Toggle Analog/Digital
- 16 – Dwell Time: Touch to Set, Enabled in Settings
- 17 – Elapsed Test Time Display
- 18 – HV Button, press to Start/Stop test
- 19 – Up/Down Buttons, touch to adjust HV in test

**Note, HV ON/OFF Button will be grayed out until E-Stop is OFF, Interlock Circuit is CLOSED, Power input is connected, and the Amplifier turns on.**

1. Before starting the test, confirm Ungrounded-Specimen-Test (UST) or Grounded-Specimen-Test (GST) Current Measurement Circuit option. If the test specimen's return is ungrounded, select UST, and refer to section 5.1.2. If the test specimen's return is grounded, select GST, and refer to section 5.1.1.

### 1. Example Operation Interface with High Voltage On

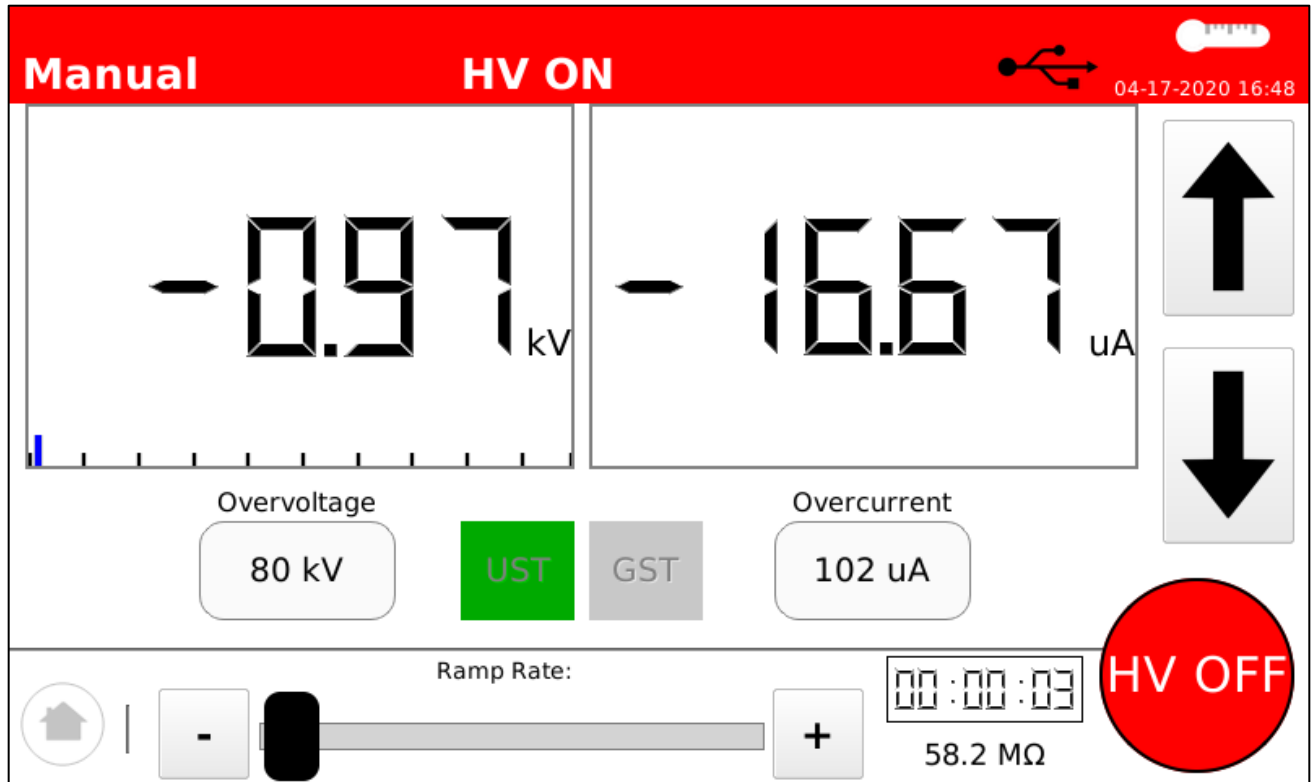

In the image above, the unit is in operation in Manual mode. The HV ON/OFF button is red, indicating the presence of high voltage. The test circuit mode, target voltage, and leakage current threshold are set and cannot be changed during operation. Meter displays can be toggled between analog and digital during testing. Resistance is calculated automatically.

## Operating the Equipment

### AUTOMATIC Test with Analog Meter Display

	Ramp	V	Dwell
1	1 kV/s	20 kV	00:10:00
2	2 kV/s	40 kV	00:01:00
3	3 kV/s	60 kV	00:01:00
4	3 kV/s	80 kV	00:00:00

- 1 – Ramp Rate, select cell to edit
- 2 – Target Voltage, select cell to edit
- 3 – Dwell Time, select cell to edit

- 4 – Preset, select to load/view/save
- 5 – Add or Remove steps

### Setting up an Automatic Test

1. Input Overvoltage and overcurrent level
2. Input Target Voltage: (0.1 → 80 kV)
3. Input Ramp Rate (0.1 → 3.0 kV per second)
4. Input Dwell Time (00:00 → 60:00 min)
5. Add/Remove additional steps in multi-step sequence
6. Confirm GST or UST mode
7. After all parameters are entered, Press HV ON to start High Voltage and begin Test

The Test will end when the Target Voltage is reached and the Dwell Time reaches 0:00

or when the Max Leakage current limit is reached.

To turn off High Voltage at any time, press STOP, engage the E-STOP, or open the Interlock Circuit.

## MANUAL Test with Analog Meter Display

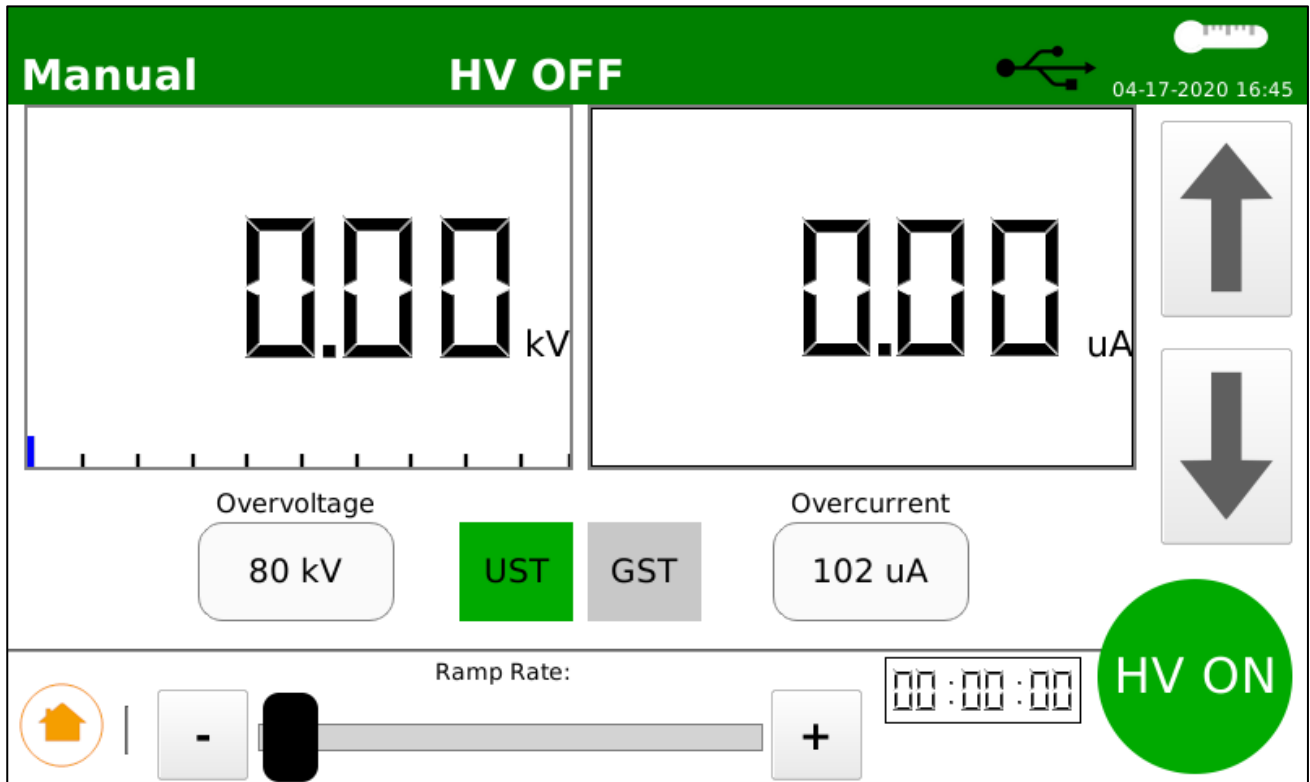

### Setting up a Manual Test

1. Input Overvoltage (0.1 → 80kV)
2. Input Overcurrent (0.1 → 10,000 $\mu$ A or 0-10mA)
3. Confirm GST or UST mode
4. Press HV ON
5. Turn Rotary Knob or touch Up-Arrow button to activate and adjust High Voltage

To turn off High Voltage at any time, press STOP, engage the E-STOP, or open the Interlock Circuit .

**Note: When performing withstand tests on cable, Manual mode is recommended. At the conclusion of the test, ramp the voltage back down to Zero before pressing STOP.**

## 6.3 Settings

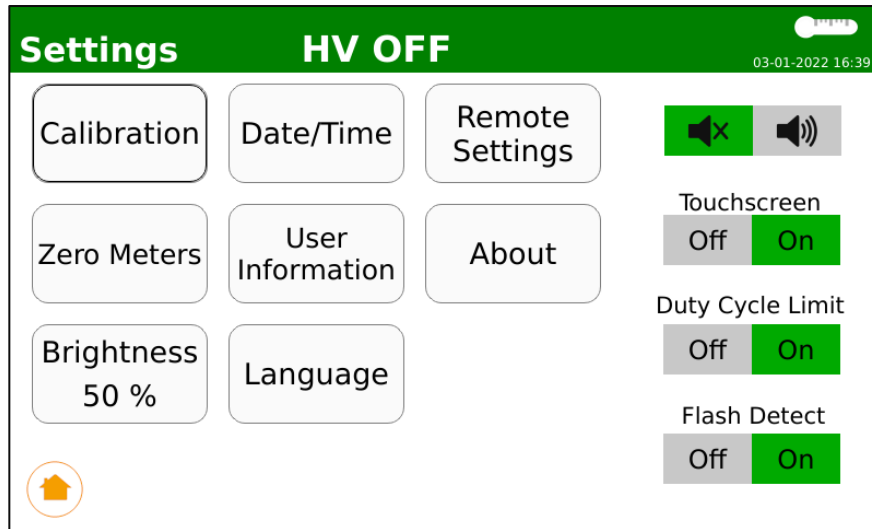

**Calibration:** To proceed to the Calibration menu, a prompt will appear for a passcode. Please contact Hipotronics for this information.

**Zero Meters:** Tare the voltage and current meters. Please make sure nothing is connected to the output cable and return port when this button is pressed.

**Brightness:** Adjust the screen brightness level

**Date/Time:** Edit the system date and time

**User Information:** Enter any identifier information for this particular unit

**Language:** Select the system display language

**Remote Settings:** Configure the WiFi-Direct settings to connect to HIPODirect

**About:** Unit Specific Information

**Buzzer Audio:** Select to disable/enable the internal buzzer which will beep while High Voltage is on.

**Touchscreen:** Select to disable/enable the touchscreen. If disabled, the unit will only be operable via the encoder knob.

**Duty Cycle Limit:** Select to enable the feature that automatically ends a test once the rated duty cycle limit has been reached. It is highly recommended that this feature remains on for the protection and longevity of the unit.

**Flash Detect:** Select to enable the feature that automatically ends a test once a flashover or DUT failure is detected. It is highly recommended that this feature remains enabled for the protection and longevity of the unit.

# 6.4 Test Reports

## (a) Accessing Test Reports

Test reports can be accessed from the main menu by touching the 'Reports' button from the main menu





## (b) Reports Menu

**Reports** **HV OFF** 03-01-2022 16:39

Select a Test

	Name	Test Mode	Date Time
1	Test Stopped_4	AUTO	01-03-2022;16:40:07
2	Test Stopped_2	MANUAL	01-03-2022;16:39:52

 **Export All**  **Delete All**

Test reports are organized by time, with the most recent at the top. From this menu, the user can select a test report, scroll down, or return to the main menu. Options may be selected by touch or the rotary knob.

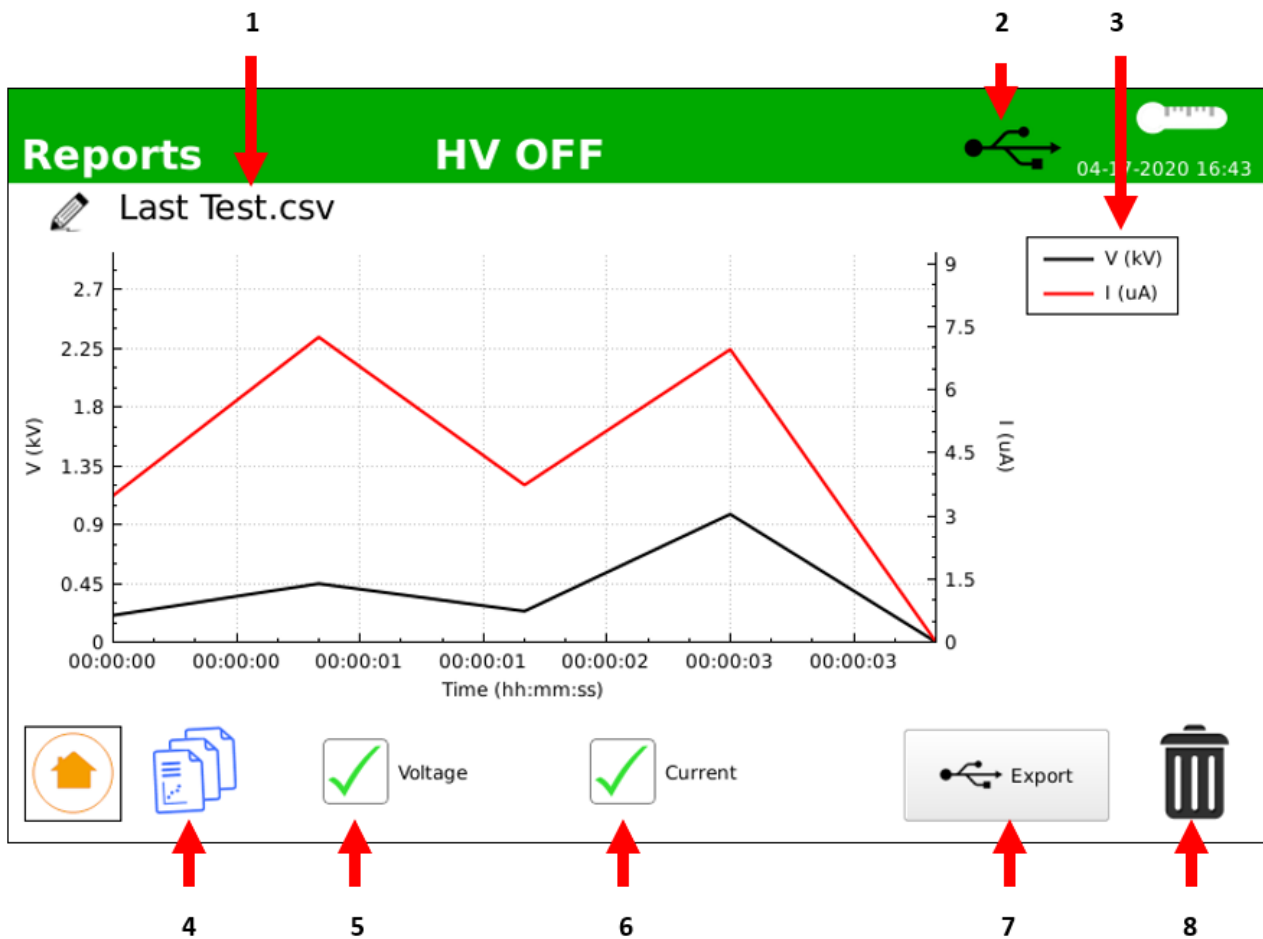

- 1 – Name of Saved Test Report, click to edit
- 2 – USB Drive Detected, if shown
- 3 – Graph Legend

- 4 – Return to Reports List
- 5 – Voltage Display, press to toggle
- 6 – Current Display, press to toggle
- 7 – Export Report to USB Drive, if detected
- 8 – Delete test report

### (c) Exporting Test Reports

To export test reports, insert a portable USB drive formatted to FAT32. If the USB drive is detected, the USB symbol will display in the top bar. From the test report screen, touch the 'Export' button, which will be active only if a USB drive is detected. A message should appear to confirm successful transfer. The files transferred will be an image of the graph (in .png format) as well as the raw data used to calculate (in .csv format).

## 6.5 HIPODirect

HIPODirect is HIPOTRONICS software app solution to wirelessly connect a mobile device to WiFi-direct capable products. Once connected the software can show product details, as well as view and download test reports. Once downloaded, the test reports can be easily shared in CSV format via e-mail or by uploading them to any cloud service. HIPODirect is also capable of downloading and installing the latest firmware available on any Hipotronics products connected via the software app.

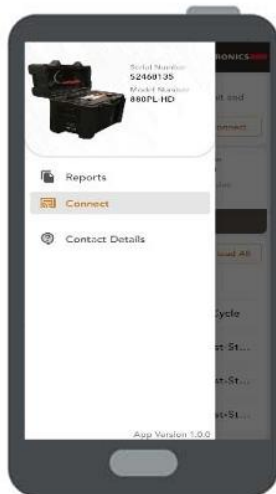

### FEATURES

- Friendly and intuitive user interface**
- Share test reports in CSV format** via e-mail or by uploading them to an online cloud
- View test report details** right on the app! Max voltage, max current, elapsed time, voltage and current graphs
- Update Hipotronics equipment** to the latest firmware available

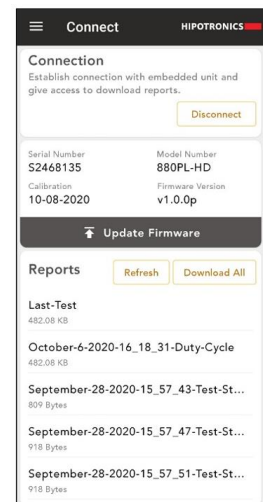

Download the free mobile app today, available on Google Play Store or Apple App Store





Contact HIPOTRONICS sales for information about the HIPODirect+ Premium software for additional enhanced features

# 7 Troubleshooting

## 7.1 Diagnostics

ISSUE	CAUSE	SOLUTION
Unit does not power on	<ol style="list-style-type: none"> <li>No Input power</li> </ol>	<ol style="list-style-type: none"> <li>Verify that input power is on.</li> <li>Verify power cord is connected to input source and HVT</li> <li>Power switch is in the ON position.</li> <li>Check fuse ( 250VAC, 10A)</li> <li>Consult factory</li> </ol>
Touchscreen unresponsive	<ol style="list-style-type: none"> <li>Touch screen disabled in "Settings"</li> <li>Screen damaged</li> </ol>	<ol style="list-style-type: none"> <li>Use rotary knob (See page 3, note 12) to navigate to "Settings", Select "System" tab . Select " Enable Touch"</li> <li>Consult factory</li> </ol>
Screen too dim	<ol style="list-style-type: none"> <li>Brightness level low</li> </ol>	<ol style="list-style-type: none"> <li>Navigate to "Settings". Select "System" tab . Select " Brightness". Adjust brightness as desired with rotary knob or touch control.</li> </ol>
Cannot initiate high voltage ( "Start" button is gray)	<ol style="list-style-type: none"> <li>System is initializing</li> <li>Interlocks are open</li> <li>  </li> </ol>	<ol style="list-style-type: none"> <li>Wait until "Start" button is green (about 5 seconds)</li> <li>Twist E-stop clockwise</li> <li>Insert interlock plug in External Interlock Input (See page 3, note 10.)</li> <li>If applicable, press and hold hand-switch or foot-switch.</li> </ol>
No high voltage output (Automatic Mode)	<ol style="list-style-type: none"> <li>System in self-protect mode.</li> <li>High voltage power supply damaged</li> </ol>	<ol style="list-style-type: none"> <li>Power off HVT, wait 2 minutes, and turn power on.</li> <li>Consult factory.</li> </ol>
No high voltage output (Manual Mode)	<ol style="list-style-type: none"> <li>User input required for this mode</li> <li>System in self-protect mode.</li> <li>High voltage power supply damaged</li> </ol>	<ol style="list-style-type: none"> <li>Turn the rotary knob or press up arrow. (See page 9, note 15.)</li> <li>Power off HVT, wait 2 minutes, and turn power on.</li> <li>Consult factory.</li> </ol>

## 7.2 Warning and Error Messages

MESSAGE	CAUSE	ACTION
TEST STOPPED	<ol style="list-style-type: none"> <li>"Stop" button pressed.</li> <li>Rotary knob pressed while "Stop" button is highlighted.</li> </ol>	<ol style="list-style-type: none"> <li>Press "Start" button only once to initiate test.</li> <li>Press Rotary knob only once to initiate test.</li> </ol>
HV OFF	<ol style="list-style-type: none"> <li>System in self-protect mode.</li> <li>High voltage power supply damaged.</li> </ol>	<ol style="list-style-type: none"> <li>Power off HVT, wait 2 minutes, and turn power on.</li> <li>Consult factory.</li> </ol>
Power Lost...Shutting Down	<ol style="list-style-type: none"> <li></li> <li>AC mains power interrupted.</li> <li>Input power cord removed.</li> <li>Power switch is set to OFF position.</li> </ol>	<ol style="list-style-type: none"> <li>Battery backup automatically engages to display metering functionality when high voltage is active. System will shut down once 0.0kV is reached. Test data is saved as last test in "Reports". Wait 2 minutes. Reestablish AC mains and power on HVT.</li> </ol>
DUT BREAKDOWN	<ol style="list-style-type: none"> <li>Arc flash across insulation detected.</li> </ol>	<ol style="list-style-type: none"> <li>Press OK or Save Report.</li> <li>Repeat test as desired.</li> </ol>
MAX LEAKAGE CURRENT EXCEEDED	<ol style="list-style-type: none"> <li>Measured leakage current exceeded the maximum limit set by the user.</li> </ol>	<ol style="list-style-type: none"> <li>Press OK or Save Report.</li> <li>Repeat test as desired.</li> </ol>
E-STOP PRESSED	<ol style="list-style-type: none"> <li>E-STOP button engaged.</li> <li></li> </ol>	<ol style="list-style-type: none"> <li>Press OK or Save Report.</li> <li>Twist E-stop clockwise to release/disengage.</li> </ol>
INTERLOCK REMOVED	<ol style="list-style-type: none"> <li>External interlock removed.</li> <li></li> </ol>	<ol style="list-style-type: none"> <li>Insert interlock plug in External Interlock Input.</li> <li>If applicable, press and hold hand-switch or foot-switch.</li> </ol>
TEST PASSED	<ol style="list-style-type: none"> <li>Test completed; DUT meets input criteria.</li> </ol>	<ol style="list-style-type: none"> <li>Press OK or Save Report.</li> </ol>
DUTY CYCLE EXCEEDED	<ol style="list-style-type: none"> <li>Test process exceeded the maximum duty cycle</li> <li>Amplifier overheating</li> <li></li> </ol>	<ol style="list-style-type: none"> <li>Wait 30 minutes for cooldown</li> </ol>

# 8 Miscellaneous

---

## 8.1 Care and Maintenance

The HVT instrument is basically service free, as long as the specified environmental conditions are adhered to. As a result, service and maintenance is restricted to cleaning of the equipment and calibration at intervals stipulated by the application for which the instrument is used.

The insulation of all cables should be periodically checked for damage. If any damage to the insulation is detected then a new measuring cable should be ordered from HIPOTRONICS.

### 8.1.1 Cleaning the Instrument

The instrument should be cleaned with a lint free cloth, slightly moistened using mild household cleanser, alcohol or spirits. Caustic cleansers and solvents (Trio, Chlorothene, etc.) should definitely be avoided.

In particular, the protective glass of the display should be cleaned from time to time with a soft, moist cloth such as used by opticians.

### 8.1.2 Instrument Calibration

When delivered new from the factory, the instrument is calibrated in accordance with the calibration report provided. A periodical calibration of the instrument every two years is recommended.

As the calibration process is fairly extensive, the instrument can only be calibrated and, if necessary, adjusted at HIPOTRONICS's factory. An updated calibration report will then be issued.

### 8.1.3 Changing Fuses

Before changing the mains fuse, remove the mains power cord. Fuses should only be replaced with the same type and value.

---

## 8.2 Instrument Storage

If the instrument is to remain unused for any length of time, it is recommended to unplug the mains lead. In addition, it is advisable to protect this high precision instrument from moisture and accumulation of dust and dirt with a suitable covering.

---

## 8.3 Packing and Transport

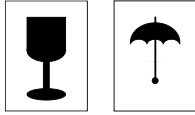

The packing of the HVT instrument provides satisfactory protection for normal transport conditions. Nevertheless, care should be taken when transporting the instrument. If return of the instrument is necessary, and the original packing crate is no longer available, then packing of an equivalent standard or better should be used.

Whenever possible protect the instrument from mechanical damage during transport with padding. Mark the container with the pictogram symbols "Fragile" and "Protect from moisture".

---

## 8.4 Recycling

When the instrument reaches the end of its working life it can, if required, be disassembled and recycled. No special instructions are necessary for dismantling.

The instrument is constructed of metal parts (mostly aluminum) and synthetic materials. The various component parts can be separated and recycled, or disposed of in accordance with the associated local rules and regulations.

# 9 Customer Support

All error messages appear on the display of the HVT measuring instrument. If persistent problems or faulty operation should occur then please contact the Customer Support Department of HIPOTRONICS or your local agent.

The Customer Support Department can be reached at the following address:

HIPOTRONICS  
Customer Service  
3030 Kutztown Rd  
Reading, PA 19605

Tel: +1 (845) 279-3644

E-mail: [service@Hipotronics.com](mailto:service@Hipotronics.com)



We prefer contact via email. Then the case is documented and traceable. Also the time zone problems and occupied telephones do not occur.



Complete information describing the problem clearly helps us to help you:

Failure description

Used settings

DUT type

Firmware Version

Serial Number

MAC address

Printouts, Pictures



Software Version & Serial No. can be found in "Settings"

---

## 9.1 Declaration of Conformity

### Hipotronics, Inc.

3030 Kutztown Rd  
Reading, PA 19605  
USA

Declared, under his own responsibility, that the below mentioned product complies with the requirements of the listed standards or other normative documents.

**So, the product complies with the requirements of the EMC directive 2014/30/EU and the low voltage directive 2014/35/EU.**

Product: **100HVT-HD**  
**HHVT-DI-CONT-HD**

Description: The HHVT-DI-CONT is a portable digital controller unit for AC high voltage transformers hipot systems. The 100HVT-HD includes the digital controller and high voltage transformer.

Standards: EN 61010-1: 2017  
EN 61326-1: 2006

Michael Carson  
Product Engineering Manager  
Hipotronics, Inc.  
3030 Kutztown Rd  
Reading, PA 19605  
USA

March 21, 2024

  
.....  
(Signature)

---

## 9.2 Warranty

HIPOTRONICS, INC. warrants to the original purchaser of any new merchandise that the merchandise is free from defects in materials and workmanship under normal use and service for a period of one (1) year from the date of shipment. The obligation of Hipotronics, Inc. under this warranty is limited, in its exclusive option, to repair, replace or issue credit for parts or materials which prove to be defective, and is subject to Purchaser's compliance with the Hipotronics, Inc. Warranty Claim Procedure as set forth below. The happening of any one or more of the following events will serve to void this warranty and any defect or damage resulting therefrom is specifically excluded from Warranty coverage:

- (a) defects due to accident, negligence, alteration, modification, faulty installation, abuse or misuse by Purchaser or Purchaser's agents or employees.
- (b) attempted or actual dismantling, disassembling, service or repair by any person, firm or corporation not specifically authorized in writing by Hipotronics, Inc.
- (c) defects caused by or due to handling by carrier or incurred during shipment, transshipment or other move.

This Warranty covers only those parts and/or materials deemed by Hipotronics, Inc. to be defective within the meaning of this Warranty. The liability of Hipotronics, Inc. shall be limited to the repair, replacement or issuance of credit for parts deemed defective within the meaning of this Warranty. Costs incurred by purchaser for labor or other expenses incidental to the inspection, repair, replacement or issuance of credit for such parts and/or materials shall be the sole responsibility of purchaser. This Warranty shall not apply to any accessories, parts or materials not manufactured or supplied by Hipotronics, Inc. and if, in the sole discretion of Hipotronics, Inc., Purchaser's claim relates to any materials of a component part, or of the manufacturer of a device of which the defective part is a component, Hipotronics, Inc. reserves the right to disclaim liability under this Warranty and to direct that the Purchaser deal directly with such supplier or manufacturer. Hipotronics, Inc. agrees to assist the purchaser in processing or settling any such claim without prejudicing its position as to liability purchaser in processing or settling any such claim without prejudicing its position as to liability.

### **Warranty Claim Procedure**

Compliance with the following Warranty Claim Procedure is a condition precedent to the obligation of Hipotronics, Inc. under this Warranty.

- (a) Purchaser must notify Hipotronics, Inc. in writing by certified or registered mail, of the defect claimed within twelve (12) months after the date of original shipment. Said notice shall describe in detail the defect, the defective part and the alleged cause of the defect.
- (b) At the exclusive option of Hipotronics, Inc., Purchaser shall dismantle or disassemble at Purchaser's cost and expense and shall ship the defective part or material, prepaid, to Hipotronics, Inc., Brewster, New York 10509, for inspection, or permit an authorized service representative of Hipotronics, Inc. to inspect the defective part or material at the Purchaser's premises. Purchaser shall provide facilities for, and at Purchaser's cost and expense, dismantle, disassemble, or otherwise make accessible the subject part or material whether or not same is a component of, or installed in, a device other than that manufactured or supplied by Hipotronics, Inc. If disclosure shows that the defect is not one for which Hipotronics, Inc. is liable, the Purchaser agrees to reimburse Hipotronics, Inc. for all expense incurred.
- (c) Upon receipt of the defective part or material, or after access to same, Hipotronics, Inc. shall inspect the part or material to determine the validity of Purchaser's claim.

The validity of any Warranty Claim, Purchaser's compliance with Hipotronics, Inc. Warranty Claim Procedure, the obligation to either repair, replace or issue credit, or direct the purchaser to deal directly with a manufacturer or supplier are to be determined solely and exclusively by Hipotronics, Inc. any determination so made shall be final and binding.

**THIS WARRANTY IS EXPRESSLY IN LIEU OF ALL OTHER WARRANTIES EXPRESSED OR IMPLIED ON THE PART OF HIPOTRONICS, INC., INCLUDING THE WARRANTIES OF MERCHANTABILITY AND FITNESS FOR USE AND CONSEQUENTIAL DAMAGES ARISING FROM ANY BREACH THEREOF AND HIPOTRONICS, INC. NEITHER ASSUMES NOR AUTHORIZES ANY OTHER PERSON, FIRM OR CORPORATION TO ASSUME ANY LIABILITY OR OBLIGATION IN CONNECTION WITH THIS SALE ON ITS BEHALF AND PURCHASER ACKNOWLEDGES THAT NO REPRESENTATIONS EXCEPT THOSE MADE HEREIN HAVE BEEN MADE TO PURCHASER.**